

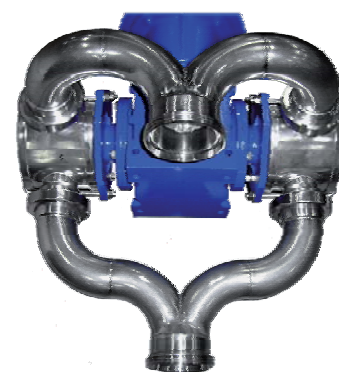

RID MINOR 40
RID MAJOR 60
RID MAXI 80



RID MAXI Double



RID MAXI Double 2Q

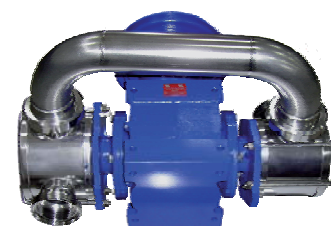

RID MAXI Double 2H

Tipo Type	Motore * Motor *	kW	Velocità Speed	Giri/min RPM	H = Prevalenza (metri) / Head (meters)											
					0	4	8	12	14	16	18	20	22	24	32	40
RID MINOR 40	TF	1.5	1	280	2200	2000	1700	1200	830	500	0					
	TF	1.5	1	350	2750	2500	2100	1600	1100	800	0					
	TF	2.2	1	560	4250	4000	3600	2900	2500	2000	1400	750	0			
	TF	1.5	1	700	5000	4700	4300	3700	3300	3000	2520	1800	850	0		
	TF	2.2	2	560	4250	4000	3600	2900	2500	2000	1400	750	0			
	TF	1.5	2	280	2200	2000	1700	1200	830	500	0					
RID MAJOR 60	TF	2.2	1	235	6300	5100	3250	0								
	TF	2.2	1	280	7000	5800	4100	1750	0							
	TF	2.2	1	350	9000	7800	6000	3700	2000	0						
	TF	2.2	1	470	12000	10500	8700	5100	3600	0						
	TF	2.2	1	560	14000	12000	9500	6000	4000	0						
	TF	2.2	1	700	18000	15000	12000	8400	5700	2500	0					
	TF	2.2	2	470	12000	10500	8700	5100	3600	0						
	TF	1.5	2	235	6300	5100	3250	0								
	TF	2.2	2	560	14000	12000	9500	6000	4000	0						
	TF	1.5	2	280	7000	5800	4100	1750	0							
RID MAXI 80	TF	2.2	2	700	18000	15000	12000	8400	5700	2500	0					
	TF	1.5	2	350	9000	7800	6000	3700	2000	0						
	TF	4	1	235	19200	18000	14700	9600	0							
	TF	4	1	300	24600	22200	18900	12000	7600	0						
	TF	4	1	470	36000	34200	30000	24000	19000	12000	0					
	TF	4	1	600	43800	41400	36000	30000	23500	16000	0					
RID MAXI Double 2Q	TF	4.5	2	470	36000	34200	30000	24000	19000	12000	0					
	TF	3.3	2	235	19200	18000	14700	9600	0							
RID MAXI Double 2H	TF	4.5	2	600	43800	41400	36000	30000	23500	16000	0					
	TF	3.3	2	300	24600	22200	18900	12000	7600	0						
RID MAXI Double 2Q	TF	5.5	1	470	72000	65000	56500	45000	38000	30000	20000	0				
	TF	3	2	235	36000	33000	27900	20500	16000	10000	0					
RID MAXI Double 2H	TF	5.5	1	470	36000	35000	34000	32000	30000	29700	28400	27000	24600	23600	14300	0
	TF	3	2	235	19200	18500	18000	16200	15000	14300	13200	12000	10000	9000	0	

Q = Portata (litri/ora) / Capacity (liters/hour)

* TF = trifase / three-phase - CC = corrente continua / direct current

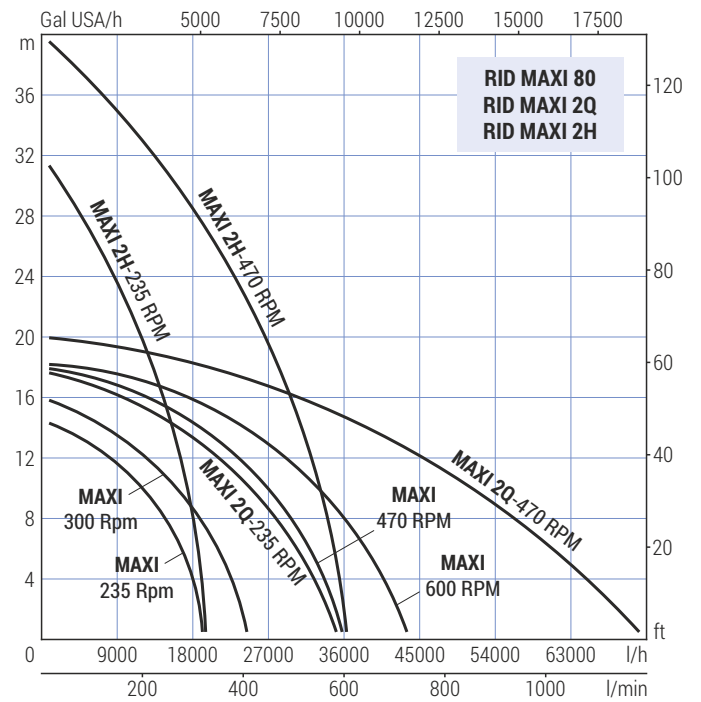
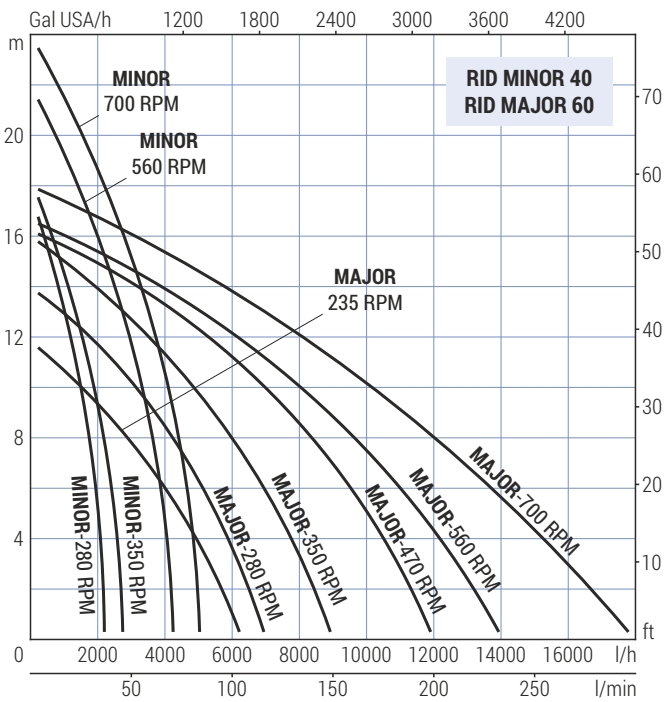

RID MINOR 40
RID MAJOR 60
RID MAXI 80

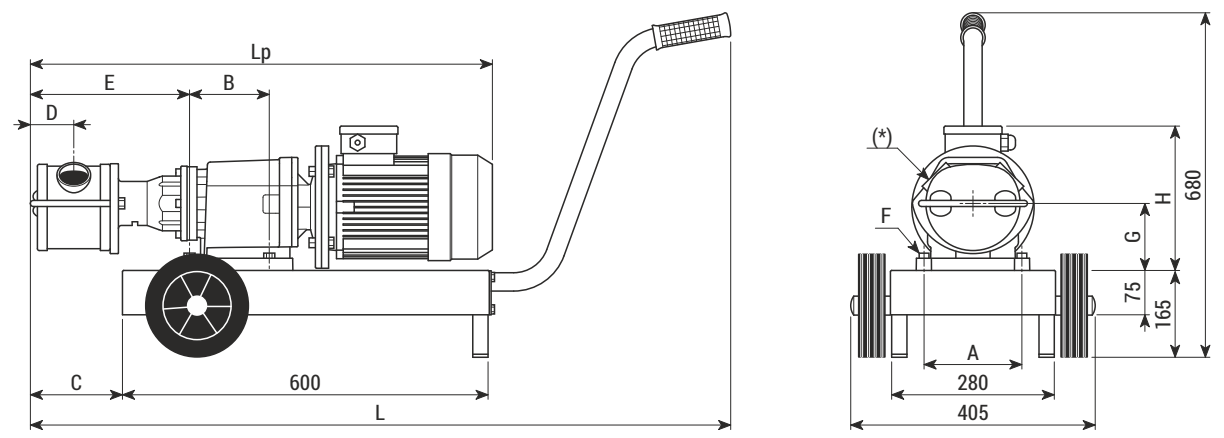

Tipo Type	Peso Weight	Dimensioni (mm) / Dimensions (mm)									
		A	B	C	D	E	F	G	H	L	Lp
RID MINOR 40	42 kg	130	107.5	64	58.4	194	Ø11	100	232.5	1101	652
RID MAJOR 60	44 kg	160	130	150.6	71	258	Ø11	105.6	236	1188	756
RID MAXI 80	65 kg	180	105	113	88	221	Ø14	130	304	1150	783

RID MAXI Double 2Q
RID MAXI Double 2H
Peso-Weight 185÷200 kg

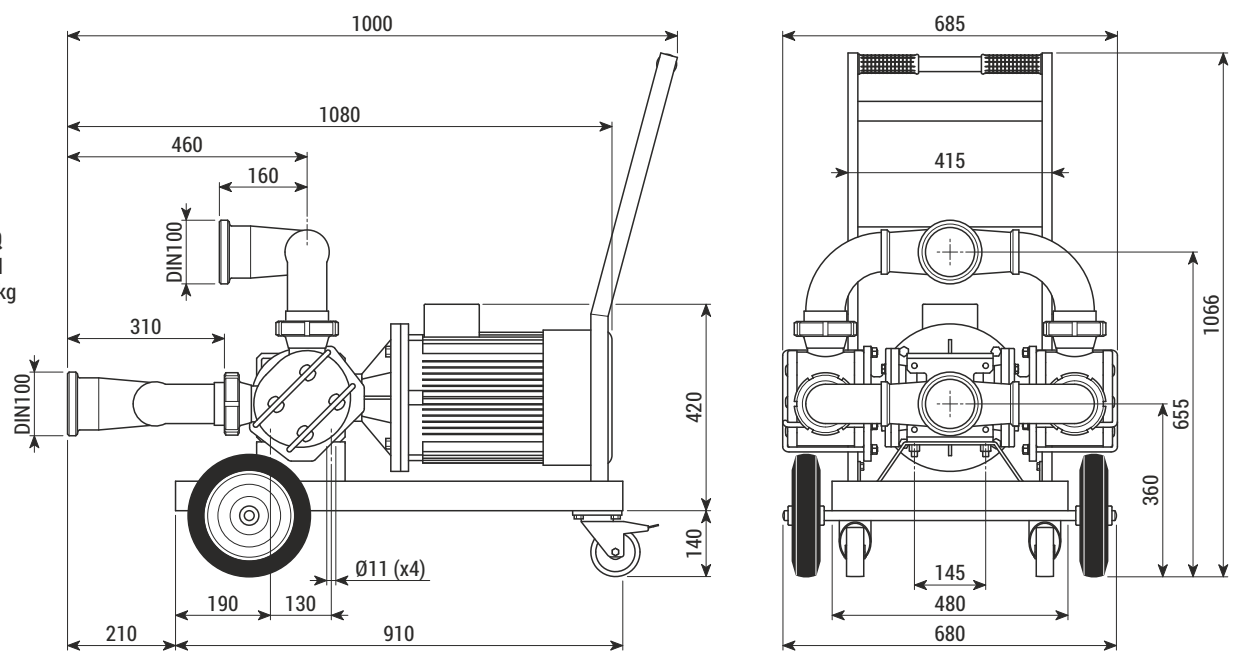

* raccordi disponibili p.21 / available pipe fittings p.21