

**HBL****HBL-X**
*(Acciaio Inox / Stainless Steel)***DESCRIZIONE E APPLICAZIONI**

Ventilatori elicoidali (assiali) largamente utilizzati sulle imbarcazioni per l'aspirazione e la ventilazione di aria nei locali chiusi (WC, cucine, sala macchine, ecc.).

CARATTERISTICHE COSTRUTTIVE

- Carcassa:
Serie **HBL**: lamiera di acciaio verniciato.
Serie **HBL-X**: acciaio inox.
- Ventola: costruita in polipropilene (temperatura di esercizio: -5°C + 80°C), dinamicamente e staticamente bilanciata.

MOTORE

- **Corrente Continua:**
Motore elettrico a magneti permanenti 12/24V, protezione IP44 (IP55 a richiesta), Classe di Isolamento F, Servizio continuo (S1).
- **Corrente Alternata:**
Motore elettrico asincrono 230V monofase (M) / 230+400V, 400+690V trifase (T), 50Hz, protezione IP54+55, Classe di Isolamento F, Servizio continuo (S1).

ACCESSORI A RICHIESTA

- Ventola in alluminio
- Ventola bi-direzionale in NYLON / VETRO in grado di garantire le stesse prestazioni in entrambe le direzioni di flusso (flusso A: ventilatore + flusso P: estrattore). Temperatura di esercizio: -35°C + 110°C.
- Rete protettiva aggiuntiva

DIREZIONI DI FLUSSO

Attenzione: la direzione di flusso, posizionamento rete protettiva e l'esecuzione del ventilatore deve essere necessariamente indicato in fase di ordine.

- **Flusso A-A1:** ventilatore
- **Flusso P-P1:** estrattore
- **Flusso B-B1:** bi-direzionale (A & P)

DESCRIPTION AND USE

Helicoidal (axial) electric blowers widely used on board for suction and ventilation of air in closed environmental (WC, kitchens, engine rooms, etc.).

CONSTRUCTION FEATURES

- *Drum casing:*
HBL series: made in painted steel sheet
HBL-X series: made in stainless steel
- *Fan:* made in polypropylene (temperature range -5°C + 80°C), dynamically and statically balanced.

MOTOR

- **Direct Current:**
Permanent magnets motor 12/24 V, Protection IP44 (IP55 on request), Insulation Class F, Continuous Duty (S1).
- **Alternate Current:**
Induction electric motor, 230V single-phase (M) / 230+400V, 400+690V three-phase (T), 50Hz, Protection IP54+55, Insulation Class F, Continuous Duty (S1).

ACCESSORIES ON REQUEST

- *Fan made in aluminium*
- *Bi-direction fan made in Nylon / Glass to grant the same performances in both directions of flux (flux A: ventilator + flux P: extractor). Temperature range: - 35°C + 110 °C.*
- *Additional protection grid*

FLUX DIRECTIONS

Attention: *the flux direction, protection grid position and the execution of the blower must be stated when the ordering.*

- **A-A1 flux:** ventilator
- **P-P1 flux:** extractor
- **B-B1 flux:** bi-directional (A & P)

Modello ** Type **	kW	Alimentazione * Feeding *	Absorbimento Absorption	Giri/min. RPM	Rumorosità Noise	Portata max Capacity max	Prevalenza max Head max
HBL 21 HBL-X 21	0.2	12V	12A	2800	65 dB	22 m ³ /min	14 mmH ₂ O
	0.2	24V	6A	2800	65 dB	22 m ³ /min	14 mmH ₂ O
	0.2	230V - 50Hz	2A	2800	72 dB	22 m ³ /min	14 mmH ₂ O
	0.2	230/400V - 50Hz	1.2-0.6A	2800	72 dB	22 m ³ /min	14 mmH ₂ O
HBL 25 HBL-X 25	0.3	12V	17A	2500	68 dB	37 m ³ /min	19 mmH ₂ O
	0.3	24V	9A	2500	68 dB	37 m ³ /min	19 mmH ₂ O
	0.37	230V - 50Hz	2.7A	2800	72 dB	42 m ³ /min	20 mmH ₂ O
	0.37	230/400V - 50Hz	1.4-0.8A	2800	72 dB	42 m ³ /min	20 mmH ₂ O
HBL 30 HBL-X 30	0.15	12V	10A	1400	60 dB	42 m ³ /min	10 mmH ₂ O
	0.15	24V	5A	1400	60 dB	42 m ³ /min	10 mmH ₂ O
	0.18	230V - 50Hz	1.8A	1400	60 dB	42 m ³ /min	10 mmH ₂ O
	0.18	230/400V - 50Hz	1.2-0.6A	1400	60 dB	42 m ³ /min	10 mmH ₂ O
HBL 30/2 HBL-X 30/2	0.37	24V	14A	2000	68 dB	75 m ³ /min	22 mmH ₂ O
	0.55	230V - 50Hz	4A	2800	74 dB	80 m ³ /min	35 mmH ₂ O
	0.55	230/400V - 50Hz	3-1.7A	2800	74 dB	80 m ³ /min	35 mmH ₂ O
HBL 35 HBL-X 35	0.15	12V	12A	1400	60 dB	62 m ³ /min	16 mmH ₂ O
	0.15	24V	6A	1400	60 dB	62 m ³ /min	16 mmH ₂ O
	0.18	230V - 50Hz	1.8A	1400	60 dB	62 m ³ /min	16 mmH ₂ O
	0.18	230/400V - 50Hz	1.2-0.6A	1400	60 dB	62 m ³ /min	16 mmH ₂ O
HBL 35/2 HBL-X 35/2	0.37	24V	16A	2000	70 dB	96 m ³ /min	22 mmH ₂ O
	1.1	230/400V - 50Hz	7.2A	2800	72 dB	100 m ³ /min	60 mmH ₂ O
	1.1	230V - 50Hz	5-2.9A	2800	72 dB	100 m ³ /min	60 mmH ₂ O
HBL 40 HBL-X 40	0.26	12V	14A	1400	65 dB	70 m ³ /min	20 mmH ₂ O
	0.26	24V	7A	1400	65 dB	70 m ³ /min	20 mmH ₂ O
	0.18	230/400V - 50Hz	1.8A	1400	65 dB	70 m ³ /min	20 mmH ₂ O
	0.18	230V - 50Hz	1.2-0.6A	1400	65 dB	70 m ³ /min	20 mmH ₂ O
HBL 40/2 HBL-X 40/2	0.55	24V	20A	2000	72 dB	130 m ³ /min	24 mmH ₂ O
	1.1	230V - 50Hz	7.2A	2800	78 dB	135 m ³ /min	70 mmH ₂ O
	1.1	230/400V - 50Hz	5-2.9A	2800	78 dB	135 m ³ /min	70 mmH ₂ O
HBL 45 HBL-X 45	0.26	24V	9A	1400	68 dB	108 m ³ /min	20 mmH ₂ O
	0.26	230V - 50Hz	2.6A	1400	68 dB	108 m ³ /min	20 mmH ₂ O
	0.26	230/400V - 50Hz	1.6-0.9A	1400	68 dB	108 m ³ /min	20 mmH ₂ O
HBL 45/2 HBL-X 45/2	0.6	24V	28A	2000	78 dB	145 m ³ /min	28 mmH ₂ O
	1.5	230V - 50Hz	9.6A	2800	82 dB	175 m ³ /min	74 mmH ₂ O
	1.5	230/400V - 50Hz	7.5-4.3A	2800	82 dB	175 m ³ /min	74 mmH ₂ O
HBL 45/2 B HBL-X 45/2 B	2.2	230V - 50Hz	7A	2800	84 dB	200 m ³ /min	90 mmH ₂ O
	2.2	230/400V - 50Hz	5.0-2.9A	2800	84 dB	200 m ³ /min	90 mmH ₂ O
HBL 50 HBL-X 50	0.75	24V	22A	1400	74 dB	160 m ³ /min	28 mmH ₂ O
	0.75	230V - 50Hz	5.1A	1400	74 dB	160 m ³ /min	28 mmH ₂ O
	0.75	230/400V - 50Hz	3.6-2.2A	1400	74 dB	160 m ³ /min	28 mmH ₂ O
HBL 50/2 HBL-X 50/2	3.0	230/400V - 50Hz	11.2-6.4A	2800	86 dB	265 m ³ /min	100 mmH ₂ O
HBL 56 HBL-X 56	0.75	24V	22A	1400	74 dB	225 m ³ /min	28 mmH ₂ O
	0.75	230V - 50Hz	5.1A	1400	74 dB	225 m ³ /min	28 mmH ₂ O
	0.75	230/400V - 50Hz	3.6-2.2A	1400	74 dB	225 m ³ /min	28 mmH ₂ O
HBL 63 HBL-X 63	1.1	230V - 50Hz	7.2A	1400	78 dB	312 m ³ /min	36 mmH ₂ O
	1.1	230/400V - 50Hz	5-2.9A	1400	78 dB	312 m ³ /min	36 mmH ₂ O
HBL 71 HBL-X 71	2.2	230V - 50Hz	9.6A	1400	80 dB	333 m ³ /min	45 mmH ₂ O
	2.2	230/400V - 50Hz	7.5-4.3A	1400	80 dB	333 m ³ /min	45 mmH ₂ O
HBL 71/B HBL-X 71/B	3.0	230/400V - 50Hz	14-8.2A	1400	82 dB	400 m ³ /min	48 mmH ₂ O
HBL 71/C HBL-X 71/C	4.0	230/400V - 50Hz	16.4-10.6A	1400	85 dB	475 m ³ /min	45 mmH ₂ O
HBL 80 HBL-X 80	3.0	230/400V - 50Hz	14-8.2A	1400	82 dB	515 m ³ /min	60 mmH ₂ O
HBL 80/A HBL-X 80/A	4.0	230/400V - 50Hz	16.4-10.6A	1400	84 dB	585 m ³ /min	50 mmH ₂ O
HBL 80/B HBL-X 80/B	5.5	230/400V - 50Hz	20.6-11.8A	1400	86 dB	635 m ³ /min	50 mmH ₂ O
HBL 80/C HBL-X 80/C	7.5	400/690V - 50Hz	14.6-8.4A	1400	88 dB	715 m ³ /min	55 mmH ₂ O
HBL 90 HBL-X 90	7.5	400/690V - 50Hz	14.6-8.4A	1400	88 dB	765 m ³ /min	90 mmH ₂ O
HBL 90/B HBL-X 90/B	11.0	400/690V - 50Hz	22.3-12.9A	1400	90 dB	875 m ³ /min	90 mmH ₂ O
HBL 100 HBL-X 100	7.5	400/690V - 50Hz	14.6-8.4A	1400	88 dB	950 m ³ /min	90 mmH ₂ O
HBL 100/B HBL-X 100/B	11.0	400/690V - 50Hz	22.3-12.9A	1400	90 dB	1100 m ³ /min	90 mmH ₂ O

* Disponibili a richiesta con altri voltaggi a 50-60Hz / Available on request with other voltages at 50-60Hz

** A richiesta disponibili altri modelli / Other product types available on request

Ventilatori elicoidali / Helicoidal blower

CORRENTE CONTINUA (c.c.) / DIRECT CURRENT (d.c.)

PRESTAZIONI / PERFORMANCES

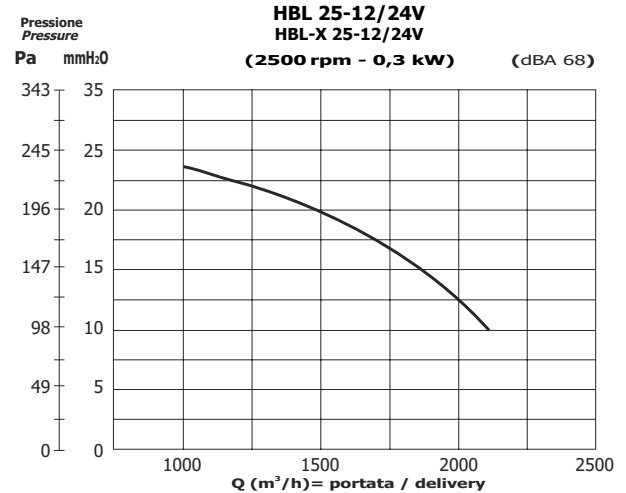
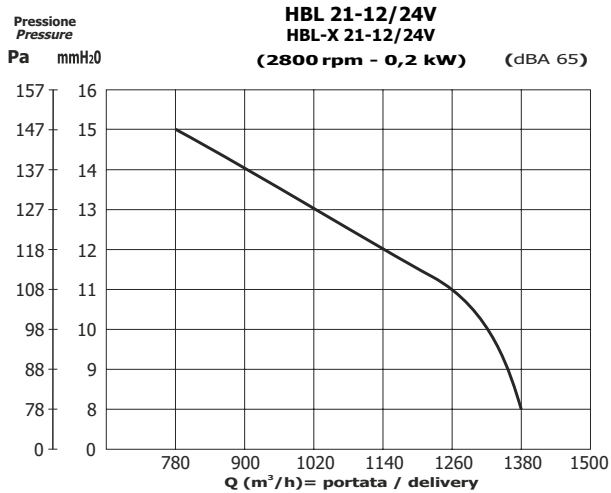

Modello Type	Vtaggio Voltage (V)	Potenza / Power		Assorbimento Absorption (A)	Giri/min. RPM	dBA	Pressione totale Total pressure	Pa	78	88	98	108	118	127	137	147	
		HP	kW					mmH ₂ O	8	9	10	11	12	13	14	15	
HBL 21 HBL-X 21	12	0,3	0,2	10	2800	65	Portata Delivery (m3/h)	1380	1350	1320	1260	1140	1020	900	780		
	24	0,3	0,2	5	2800	65		1380	1350	1320	1260	1140	1020	900	780		

Modello Type	Vtaggio Voltage (V)	Potenza / Power		Assorbimento Absorption (A)	Giri/min. RPM	dBA	Pressione totale Total pressure	Pa	98	108	127	147	167	176	196	216	225
		HP	kW					mmH ₂ O	10	11	13	15	17	18	20	22	23
HBL 25 HBL-X 25	12	0,4	0,3	16	2500	68	Portata Delivery (m3/h)	2220	2100	1940	1870	1760	1625	1500	1370	1000	
	24	0,4	0,3	9	2500	68		2220	2100	1940	1870	1760	1625	1500	1370	1000	

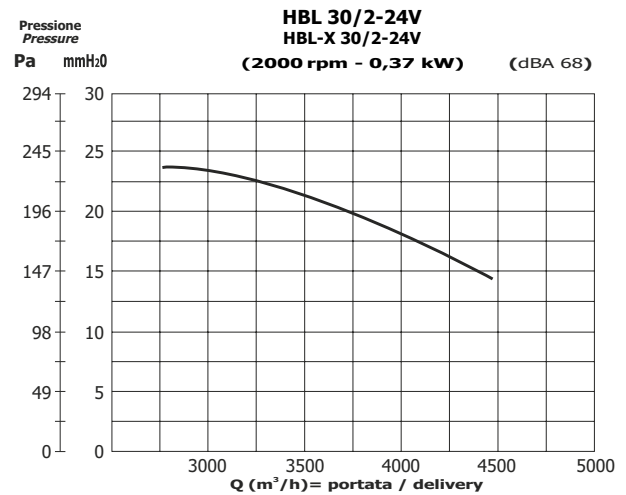
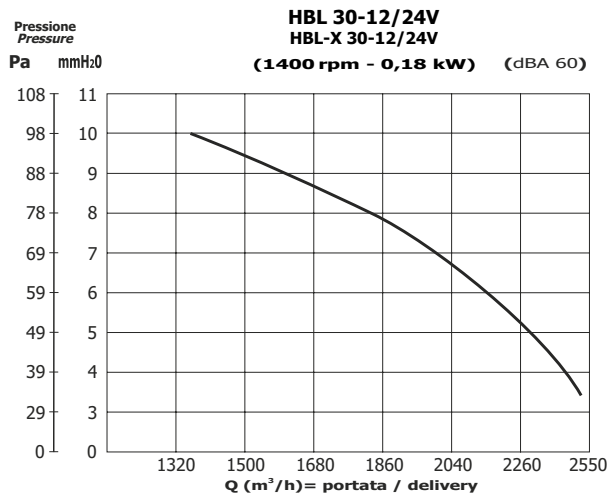

Modello Type	Vtaggio Voltage (V)	Potenza / Power		Assorbimento Absorption (A)	Giri/min. RPM	dBA	Pressione totale Total pressure	Pa	39	49	59	69	78	88	98
		HP	kW					mmH ₂ O	4	5	6	7	8	9	10
HBL 30 HBL-X 30	12	0,25	0,18	10	1400	60	Portata Delivery (m3/h)	2420	2310	2160	1995	1820	1620	1390	
	24	0,25	0,18	5	1400	60		2420	2310	2160	1995	1820	1620	1390	

Modello Type	Vtaggio Voltage (V)	Potenza / Power		Assorbimento Absorption (A)	Giri/min. RPM	dBA	Pressione totale Total pressure	Pa	137	147	173	196	221	235	245
		HP	kW					mmH ₂ O	14	15	17,5	20	22,5	24	25
HBL 30/2 HBL-X 30/2	24	0,5	0,37	14	2000	68	Portata Delivery (m3/h)	4500	4300	4100	3750	3250	2900	2750	

Ventilatori elicoidali / Helicoidal blower

CORRENTE CONTINUA (c.c.) / DIRECT CURRENT (d.c.)

PRESTAZIONI / PERFORMANCES

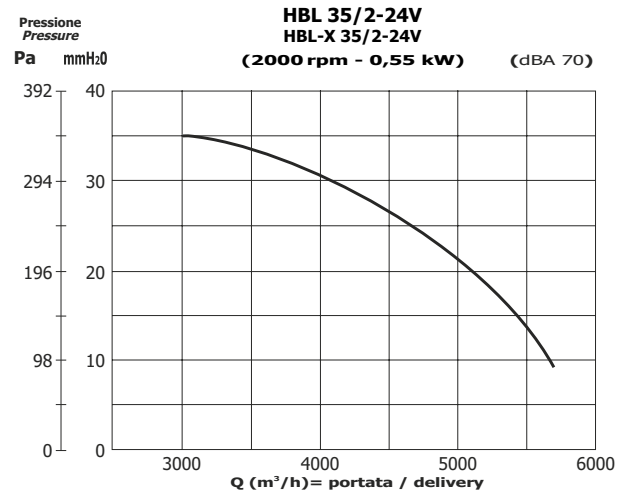
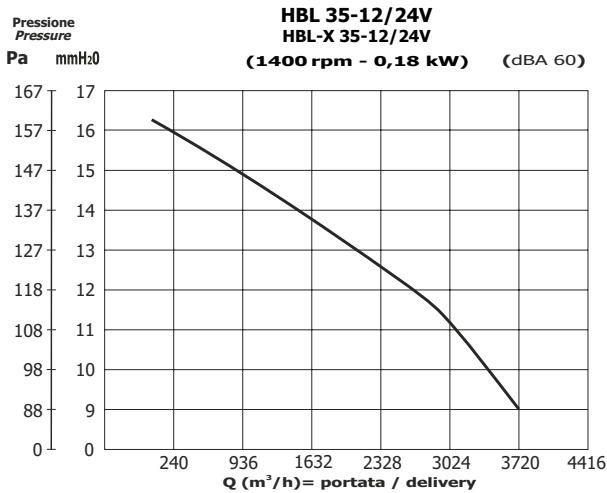

Modello Type	Vtaggio Voltage (V)	Potenza / Power		Assorbimento Absorption (A)	Giri/min. RPM	dBA	Pressione totale Total pressure	Pa	88	98	108	118	127	137	147	157	
		HP	kW					mmH ₂ O	9	10	11	12	13	14	15	16	
HBL 35 HBL-X 35	12	0,25	0,18	12	1400	60	Portata Delivery (m3/h)	3720	3380	3060	2700	2100	1500	930	240		
	24	0,25	0,18	6	1400	60		3720	3380	3060	2700	2100	1500	930	240		

Modello Type	Vtaggio Voltage (V)	Potenza / Power		Assorbimento Absorption (A)	Giri/min. RPM	dBA	Pressione totale Total pressure	Pa	98	127	147	196	245	294	343
		HP	kW					mmH ₂ O	10	13	15	20	25	30	35
HBL 35/2 HBL-X 35/2	24	0,75	0,55	16	2000	70	Portata Delivery (m3/h)	5540	5500	5400	5100	4650	4000	3000	

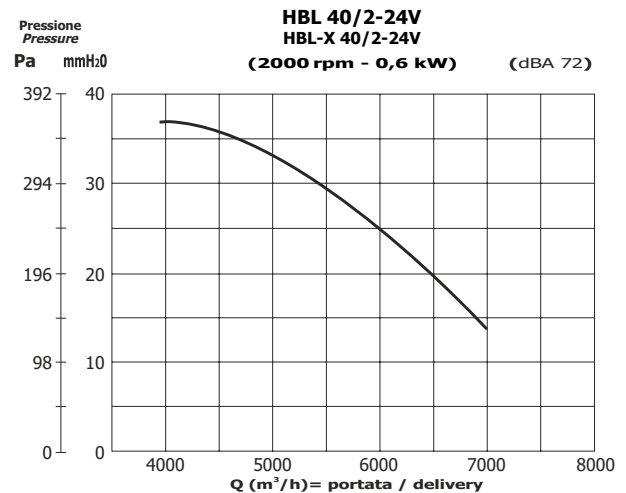
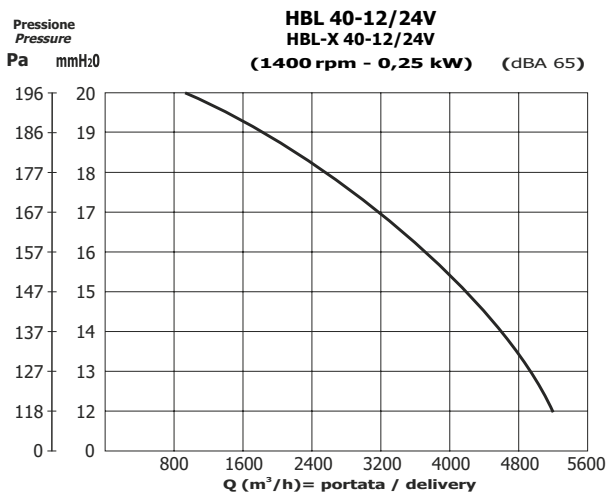

Modello Type	Vtaggio Voltage (V)	Potenza / Power		Assorbimento Absorption (A)	Giri/min. RPM	dBA	Pressione totale Total pressure	Pa	127	137	147	157	167	176	186	196
		HP	kW					mmH ₂ O	13	14	15	16	17	18	19	20
HBL 40 HBL-X 40	12	0,35	0,25	14	1400	65	Portata Delivery (m3/h)	4920	4600	4200	3650	3200	2500	1750	900	
	24	0,35	0,25	7	1400	65		4920	4600	4200	3650	3200	2500	1750	900	

Modello Type	Vtaggio Voltage (V)	Potenza / Power		Assorbimento Absorption (A)	Giri/min. RPM	dBA	Pressione totale Total pressure	Pa	137	147	196	245	294	353
		HP	kW					mmH ₂ O	14	15	20	25	30	36
HBL 40/2 HBL-X 40/2	24	0,8	0,6	22	2000	72	Portata Delivery (m3/h)	7000	6800	6500	6000	5450	4500	

Ventilatori elicoidali / Helicoidal blower

CORRENTE CONTINUA (c.c.) / DIRECT CURRENT (d.c.)

PRESTAZIONI / PERFORMANCES

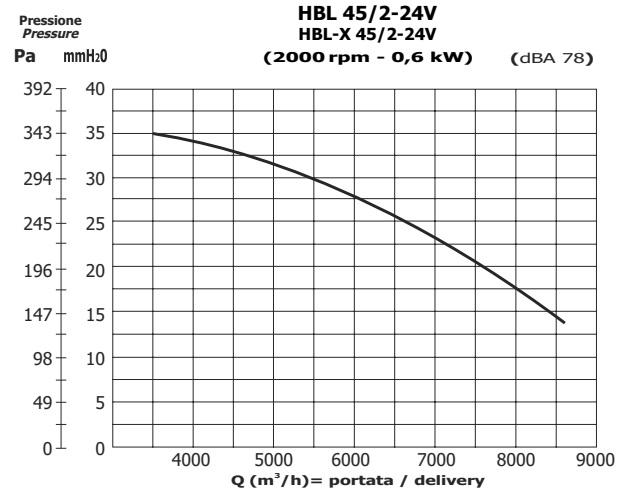
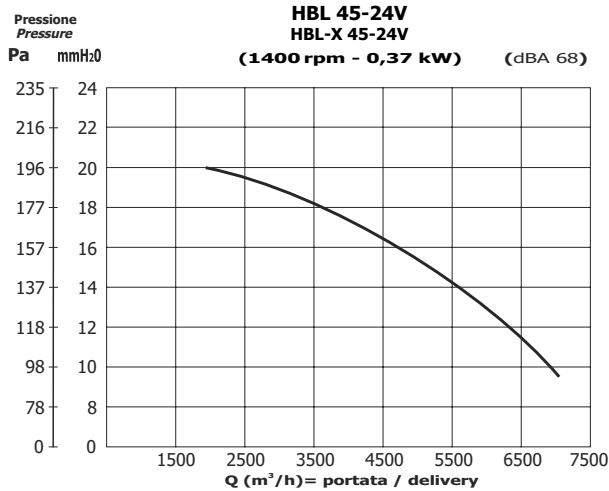

Modello Type	Vtaggio Voltage (V)	Potenza / Power		Assorbimento Absorption (A)	Giri/min. RPM	dBA	Pressione totale Total pressure	Pa	98	117	137	156	176	196
		HP	kW					mmH ₂ O	10	12	14	16	18	20
HBL 45 HBL-X 45	24	0,5	0,37	12	1400	68	Portata Delivery (m3/h)	6600	6300	5500	4700	3500	2000	

Modello Type	Vtaggio Voltage (V)	Potenza / Power		Assorbimento Absorption (A)	Giri/min. RPM	dBA	Pressione totale Total pressure	Pa	127	147	196	245	294	343
		HP	kW					mmH ₂ O	13	15	20	25	30	35
HBL 45/2 HBL-X 45/2	24	0,8	0,6	24	2000	78	Portata Delivery (m3/h)	8700	8460	7600	6650	5500	3000	

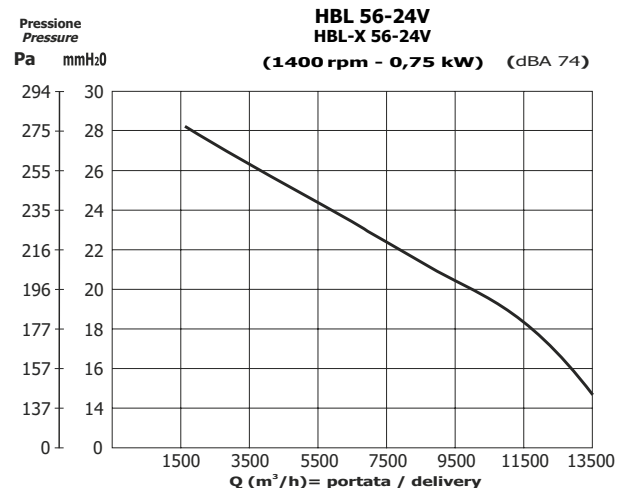
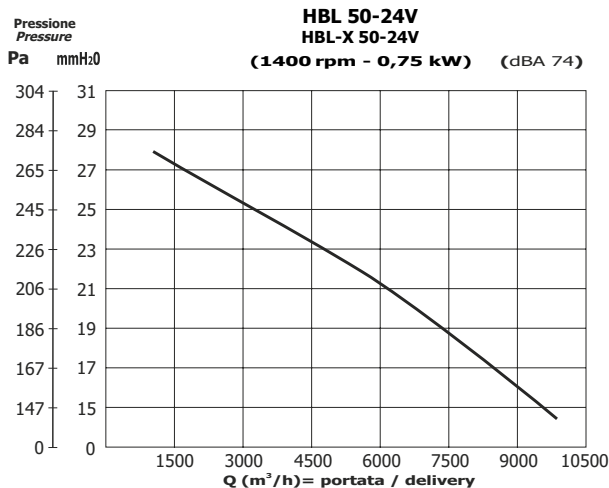

Modello Type	Vtaggio Voltage (V)	Potenza / Power		Assorbimento Absorption (A)	Giri/min. RPM	dBA	Pressione totale Total pressure	Pa	147	167	186	206	225	245	265	274
		HP	kW					mmH ₂ O	15	17	19	21	23	25	27	28
HBL 50 HBL-X 50	24	1	0,75	18	1400	74	Portata Delivery (m3/h)	9900	8400	7500	6100	4700	3150	1700	1350	

Modello Type	Vtaggio Voltage (V)	Potenza / Power		Assorbimento Absorption (A)	Giri/min. RPM	dBA	Pressione totale Total pressure	Pa	147	157	176	196	216	235	255	274
		HP	kW					mmH ₂ O	15	16	18	20	22	24	26	28
HBL 56 HBL-X 56	24	1	0,75	20	1400	74	Portata Delivery (m3/h)	13500	13000	11600	10000	7700	5700	3650	1600	

Ventilatori elicoidali / Helicoidal blower

CORRENTE CONTINUA (c.c.) / DIRECT CURRENT (d.c.)

DIMENSIONI E PESI / DIMENSIONS AND WEIGHTS

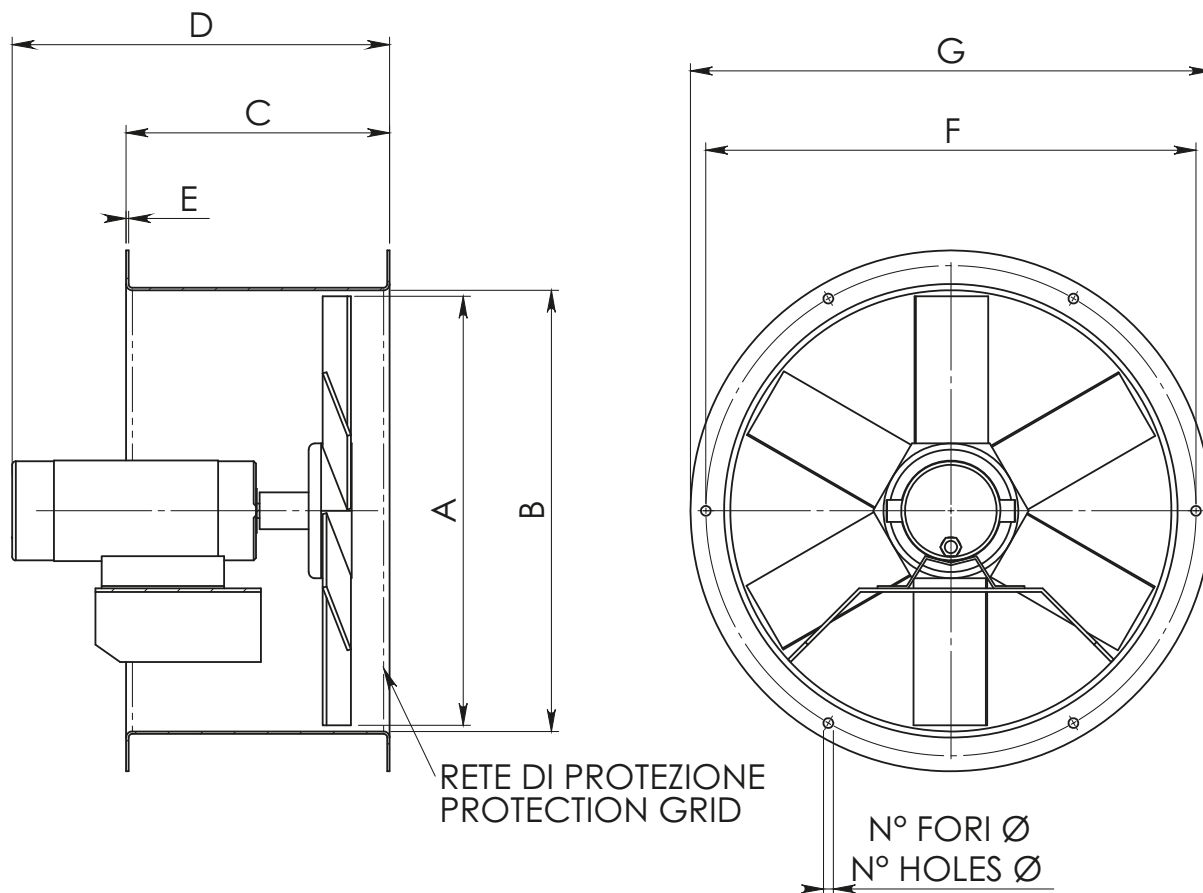

Modello Type	Corrente Current	A	B	C	D	E	F	G	Fori Holes	Peso Weight (kg)
HBL 21 HBL-X 21	c.c - d.c.	205	215	200	265	1,5	250	275	No.6 x Ø10	6
HBL 25 HBL-X 25	c.c - d.c.	250	260	200	325	1,5	285	315	No.6 x Ø10	7
HBL 30 HBL-X 30	c.c - d.c.	305	315	200	300	1,5	348	378	No.6 x Ø11	8
HBL 30/2 HBL-X 30/2	c.c - d.c.	305	315	200	330	1,5	348	378	No.6 x Ø11	10
HBL 35 HBL-X 35	c.c - d.c.	350	360	215	300	1,5	400	425	No.6 x Ø11	9
HBL 35/2 HBL-X 35/2	c.c - d.c.	350	360	215	330	1,5	400	425	No.6 x Ø11	11
HBL 40 HBL-X 40	c.c - d.c.	400	410	215	330	1,5	440	473	No.6 x Ø11	12
HBL 40/2 HBL-X 40/2	c.c - d.c.	400	410	215	370	1,5	440	473	No.6 x Ø11	14
HBL 45 HBL-X 45	c.c - d.c.	450	460	230	330	1,5	495	523	No.6 x Ø11	13
HBL 45/2 HBL-X 45/2	c.c - d.c.	450	460	230	380	1,5	495	523	No.6 x Ø11	18
HBL 50 HBL-X 50	c.c - d.c.	500	510	270	400	1,5	545	573	No.8 x Ø11	21
HBL 56 HBL-X 56	c.c - d.c.	560	570	300	400	1,5	605	633	No.8 x Ø11	24

Misure in millimetri (mm), dimensioni non impegnative / Measures in millimeter (mm), dimensions approximated

Ventilatori elicoidali / Helicoidal blower

CORRENTE ALTERNATA (c.a.) / ALTERNATE CURRENT (a.c.)

PRESTAZIONI / PERFORMANCES

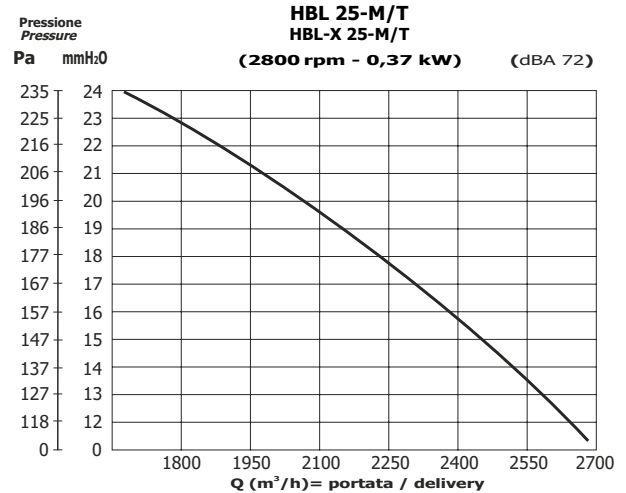
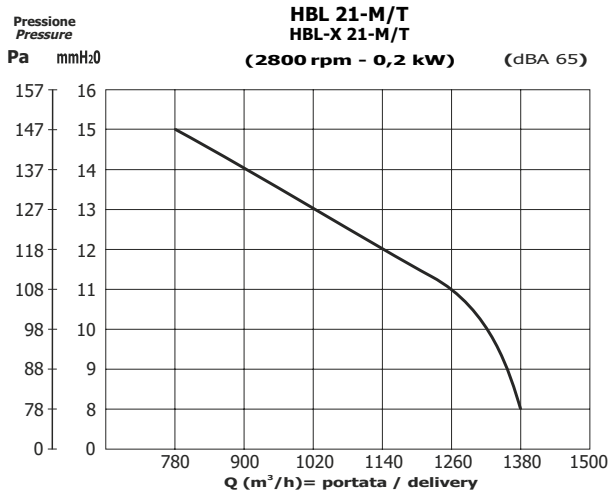

Modello Type	Vtaggio Voltage (V)	Potenza / Power		Assorbimento Absorption (A)	Giri/min. RPM	dBA	Pressione totale Total pressure	Pa	78	88	98	108	118	127	137	147
		HP	kW					mmH ₂ O	8	9	10	11	12	13	14	15
HBL 21 HBL-X 21	230M	0,3	0,2	2	2800	65	Portata Delivery (m3/h)	1380	1350	1320	1260	1140	1020	900	780	
	230+400T	0,3	0,2	1,2+0,6	2800	65		1380	1350	1320	1260	1140	1020	900	780	

Modello Type	Vtaggio Voltage (V)	Potenza / Power		Assorbimento Absorption (A)	Giri/min. RPM	dBA	Pressione totale Total pressure	Pa	118	137	157	176	186	196	206	216	225
		HP	kW					mmH ₂ O	12	14	16	18	19	20	21	22	23
HBL 25 HBL-X 25	230M	0,5	0,37	2,7	2800	72	Portata Delivery (m3/h)	2640	2500	2395	2200	2140	1980	1940	1880	1800	
	230+400T	0,5	0,37	1,4+0,8	2800	72		2640	2500	2395	2200	2140	1980	1940	1880	1800	

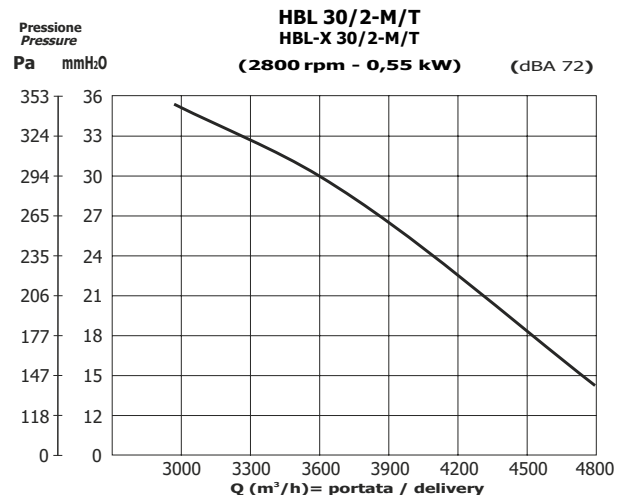
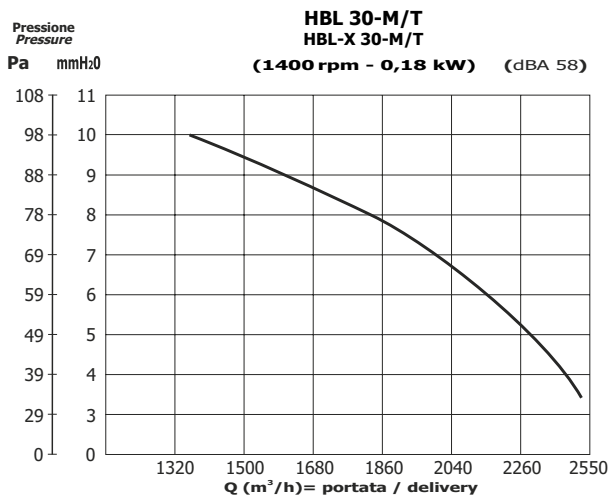

Modello Type	Vtaggio Voltage (V)	Potenza / Power		Assorbimento Absorption (A)	Giri/min. RPM	dBA	Pressione totale Total pressure	Pa	39	49	59	69	78	88	98
		HP	kW					mmH ₂ O	4	5	6	7	8	9	10
HBL 30 HBL-X 30	230M	0,25	0,18	1,8	1400	58	Portata Delivery (m3/h)	2420	2310	2160	1995	1820	1620	1390	
	230+400T	0,25	0,18	1,2+0,6	1400	58		2420	2310	2160	1995	1820	1620	1390	

Modello Type	Vtaggio Voltage (V)	Potenza / Power		Assorbimento Absorption (A)	Giri/min. RPM	dBA	Pressione totale Total pressure	Pa	137	176	206	235	265	206	343
		HP	kW					mmH ₂ O	14	18	21	24	27	30	35
HBL 30/2 HBL-X 30/2	230M	0,75	0,55	4	2800	72	Portata Delivery (m3/h)	4800	4500	4300	4080	3880	3600	3000	
	230+400T	0,75	0,55	3+1,7	2800	72		4800	4500	4300	4080	3880	3600	3000	

Ventilatori elicoidali / Helicoidal blower

CORRENTE ALTERNATA (c.a.) / ALTERNATE CURRENT (a.c.)

PRESTAZIONI / PERFORMANCES

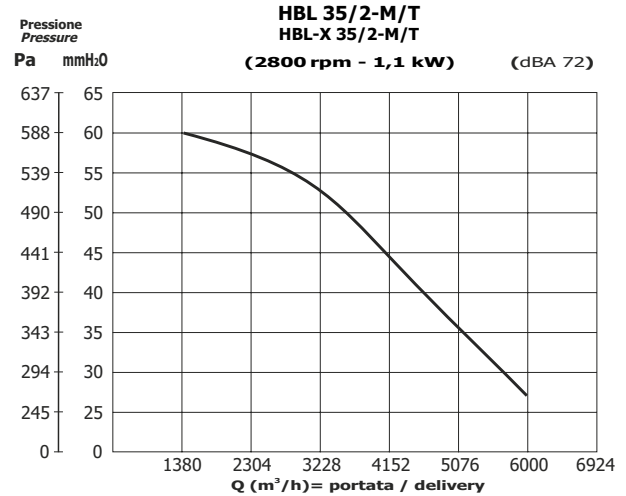
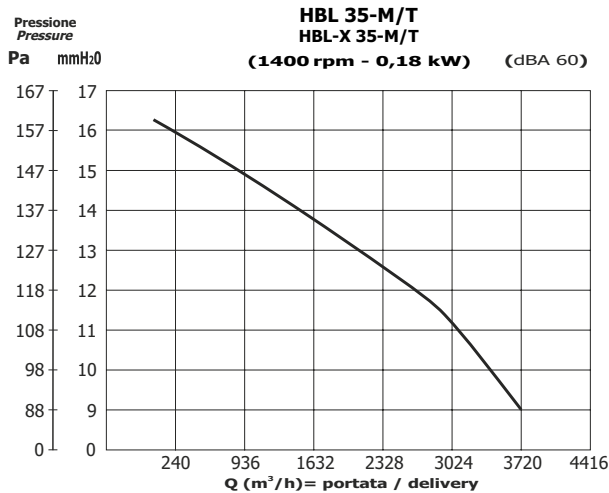

Modello Type	Vtaggio Voltage (V)	Potenza / Power		Assorbimento Absorption (A)	Giri/min. RPM	dBA	Pressione totale Total pressure	Pa	88	98	108	118	127	137	147	157	
		HP	kW					mmH ₂ O	9	10	11	12	13	14	15	16	
HBL 35 HBL-X 35	230M	0,25	0,18	1,8	1400	60	Portata Delivery (m3/h)	3720	3380	3060	2700	2100	1500	930	240		
	230+400T	0,25	0,18	1,2+0,6	1400	60		3720	3380	3060	2700	2100	1500	930	240		

Modello Type	Vtaggio Voltage (V)	Potenza / Power		Assorbimento Absorption (A)	Giri/min. RPM	dBA	Pressione totale Total pressure	Pa	265	294	343	392	441	490	539	588	
		HP	kW					mmH ₂ O	27	30	35	40	45	50	55	60	
HBL 35/2 HBL-X 35/2	230M	1,5	1,1	1	2800	72	Portata Delivery (m3/h)	6000	5620	5076	4600	4152	3580	2750	1380		
	230+400T	1,5	1,1	5+2,9	2800	72		6000	5620	5076	4600	4152	3580	2750	1380		

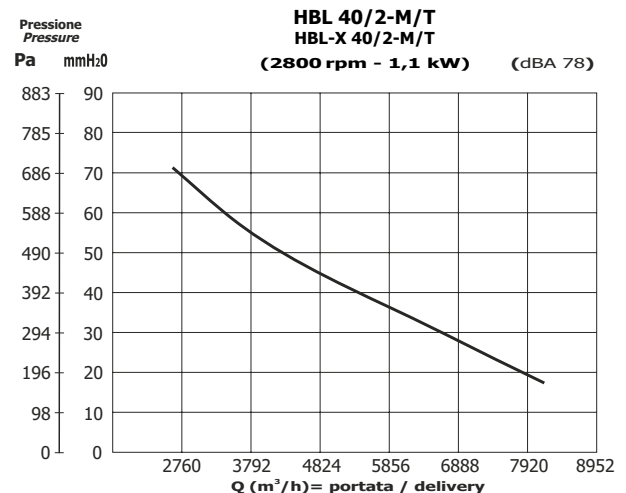
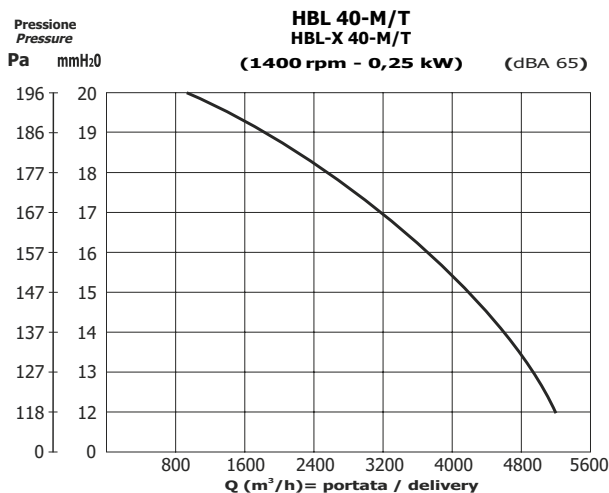

Modello Type	Vtaggio Voltage (V)	Potenza / Power		Assorbimento Absorption (A)	Giri/min. RPM	dBA	Pressione totale Total pressure	Pa	127	137	147	157	167	176	186	196	
		HP	kW					mmH ₂ O	13	14	15	16	17	18	19	20	
HBL 40 HBL-X 40	230M	0,35	0,25	1,8	1400	65	Portata Delivery (m3/h)	4920	4600	4200	3650	3200	2500	1750	900		
	230+400T	0,35	0,25	1,2+0,6	1400	65		4920	4600	4200	3650	3200	2500	1750	900		

Modello Type	Vtaggio Voltage (V)	Potenza / Power		Assorbimento Absorption (A)	Giri/min. RPM	dBA	Pressione totale Total pressure	Pa	196	235	294	392	490	588	686	
		HP	kW					mmH ₂ O	20	24	30	40	50	60	70	
HBL 40/2 HBL-X 40/2	230M	1,5	1,1	7	2800	78	Portata Delivery (m3/h)	8100	7410	6600	5340	4280	3380	2760		
	230+400T	1,5	1,1	5+2,9	2800	78		8100	7410	6600	5340	4280	3380	2760		

Ventilatori elicoidali / Helicoidal blower

CORRENTE ALTERNATA (c.a.) / ALTERNATE CURRENT (a.c.)

PRESTAZIONI / PERFORMANCES

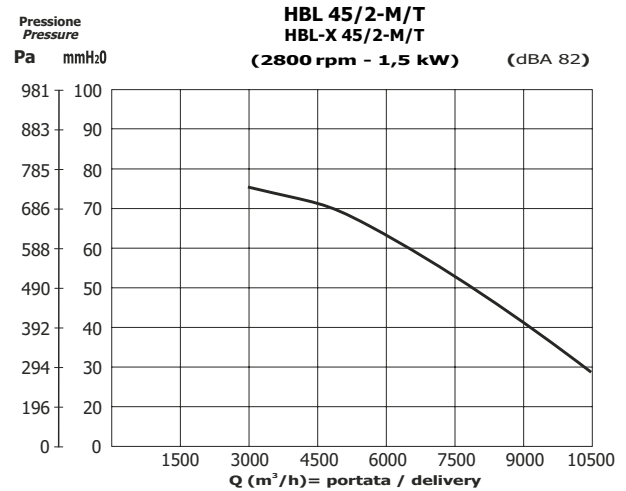
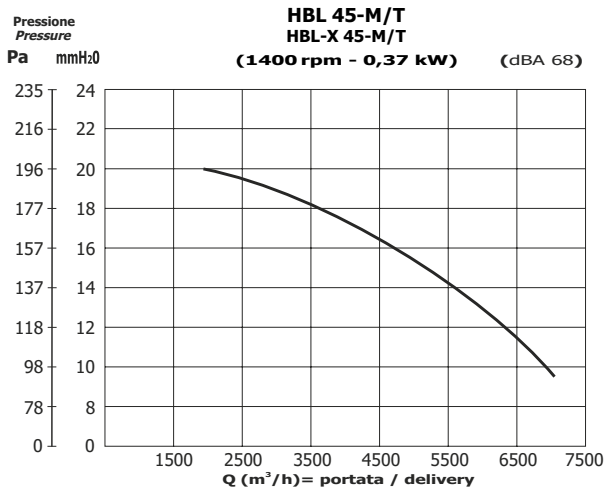

Modello Type	Voltaggio Voltage (V)	Potenza / Power		Assorbimento Absorption (A)	Giri/min. RPM	dBA	Pressione totale Total pressure	Pa	98	117	137	156	176	196
		HP	kW					mmH ₂ O	10	12	14	16	18	20
HBL 45 HBL-X 45	230M	0,5	0,37	2,6	1400	68	Portata Delivery (m ³ /h)	6600	6300	5500	4700	3500	2000	
	230+400T	0,5	0,37	1,6+0,9	1400	68		6600	6300	5500	4700	3500	2000	

Modello Type	Voltaggio Voltage (V)	Potenza / Power		Assorbimento Absorption (A)	Giri/min. RPM	dBA	Pressione totale Total pressure	Pa	294	392	490	588	686	735
		HP	kW					mmH ₂ O	30	40	50	60	70	75
HBL 45/2 HBL-X 45/2	230M	2	1,5	9,6	2800	82	Portata Delivery (m ³ /h)	10500	9000	7500	6500	4500	3000	
	230+400T	2	1,5	6,9+4,3	2800	82		10500	9000	7500	6500	4500	3000	

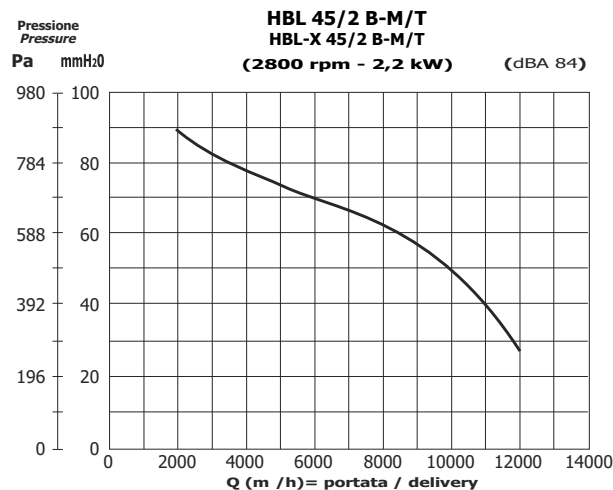

Modello Type	Voltaggio Voltage (V)	Potenza / Power		Assorbimento Absorption (A)	Giri/min. RPM	dBA	Pressione totale Total pressure	Pa	294	392	490	588	686	784	882
		HP	kW					mmH ₂ O	30	40	50	60	70	80	90
HBL 45/2 B HBL-X 45/2 B	230M	3	2,2	7	2800	84	Portata Delivery (m ³ /h)	12000	11000	10000	8500	6000	3500	2000	
	230+400T	3	2,2	5+2,9	2800	84		12000	11000	10000	8500	6000	3500	2000	

Ventilatori elicoidali / Helicoidal blower

CORRENTE ALTERNATA (c.a.) / ALTERNATE CURRENT (a.c.)

PRESTAZIONI / PERFORMANCES

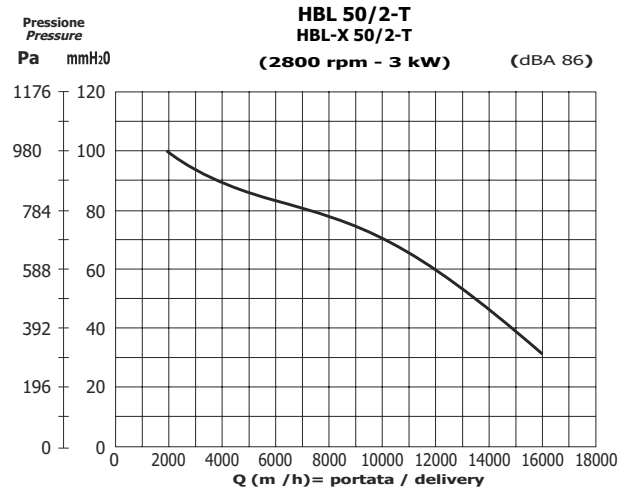
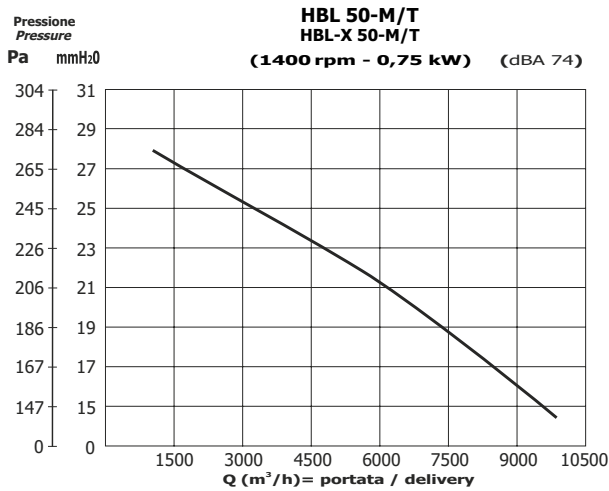

Modello Type	Voltage (V)	Potenza / Power		Assorbimento Absorption (A)	Giri/min. RPM	dBA	Pressione totale Total pressure	Pa	147	167	186	206	225	245	265	274
		HP	kW					mmH ₂ O	15	17	19	21	23	25	27	28
HBL 50 HBL-X 50	230M	1	0,75	5,1	1400	74	Portata Delivery (m3/h)	9900	8400	7500	6100	4700	3150	1700	1350	
	230÷400T	1	0,75	3,6÷2,2	1400	74		9900	8400	7500	6100	4700	3150	1700	1350	

Modello Type	Voltage (V)	Potenza / Power		Assorbimento Absorption (A)	Giri/min. RPM	dBA	Pressione totale Total pressure	Pa	294	392	588	784	980
		HP	kW					mmH ₂ O	30	40	60	80	100
HBL 50/2 B HBL-X 50/2 B	230÷400T	4	3	11,2÷6,4	2800	86	Portata Delivery (m3/h)	16000	15000	12000	7000	2000	

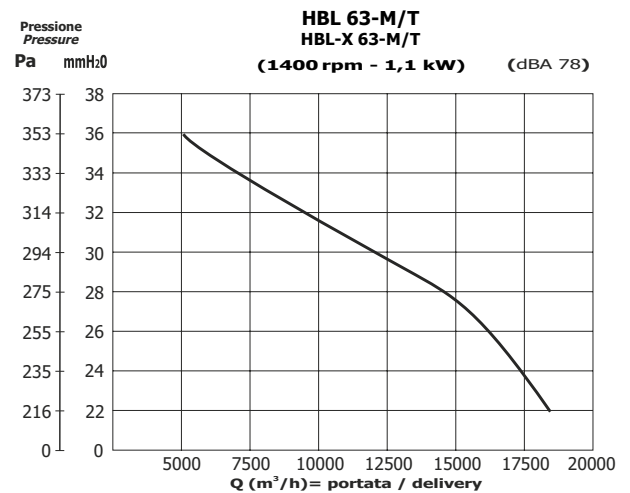
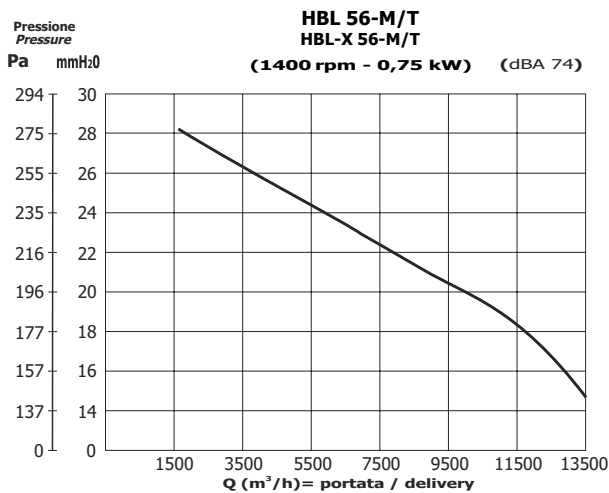

Modello Type	Voltage (V)	Potenza / Power		Assorbimento Absorption (A)	Giri/min. RPM	dBA	Pressione totale Total pressure	Pa	147	157	176	196	216	235	255	274
		HP	kW					mmH ₂ O	15	16	18	20	22	24	26	28
HBL 56 HBL-X 56	230M	1	0,75	5,1	1400	74	Portata Delivery (m3/h)	13500	13000	11600	10000	7700	5700	3650	1600	
	230÷400T	1	0,75	3,6÷2,2	1400	74		13500	13000	11600	10000	7700	5700	3650	1600	

Modello Type	Voltage (V)	Potenza / Power		Assorbimento Absorption (A)	Giri/min. RPM	dBA	Pressione totale Total pressure	Pa	216	235	255	274	294	314	333	353
		HP	kW					mmH ₂ O	22	24	26	28	30	32	34	36
HBL 63 HBL-X 63	230M	1,5	1,1	7,2	1400	78	Portata Delivery (m3/h)	18720	17500	16250	14500	12000	9400	7000	5000	
	230÷400T	1,5	1,1	5÷2,9	1400	78		18720	17500	16250	14500	12000	9400	7000	5000	

Ventilatori elicoidali / Helicoidal blower

CORRENTE ALTERNATA (c.a.) / ALTERNATE CURRENT (a.c.)

PRESTAZIONI / PERFORMANCES

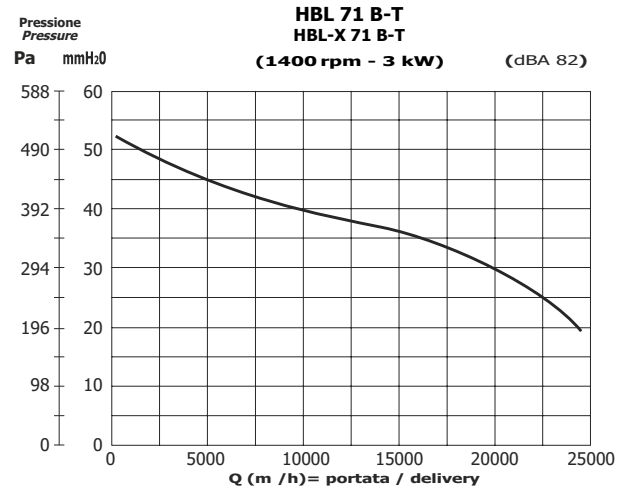
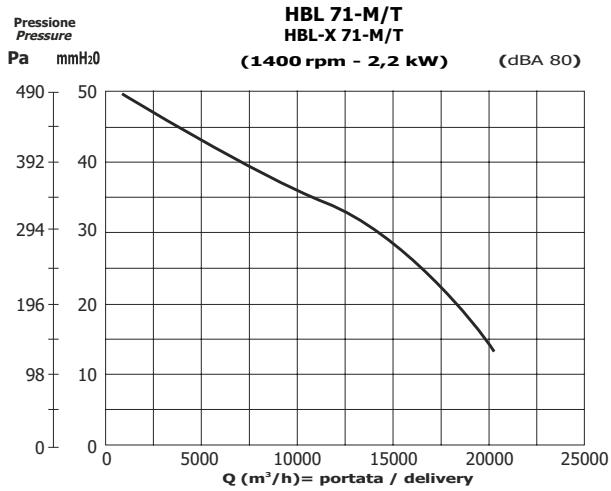

Modello Type	Vtaggio Voltage (V)	Potenza / Power		Assorbimento Absorption (A)	Giri/min. RPM	dBA	Pressione totale Total pressure	Pa	137	167	196	245	294	343	392	441	
		HP	kW					mmH ₂ O	14	17	20	25	30	35	40	45	
HBL 71	230M	3	2,2	9,6	1400	80	Portata Delivery (m ³ /h)	20000	18900	18100	16800	13800	10500	7500	3750		
HBL-X 71	230÷400T	3	2,2	7,5÷4,3	1400	80		20000	18900	18100	16800	13800	10500	7500	3750		

Modello Type	Vtaggio Voltage (V)	Potenza / Power		Assorbimento Absorption (A)	Giri/min. RPM	dBA	Pressione totale Total pressure	Pa	196	294	392	441	470,4
		HP	kW					mmH ₂ O	20	30	40	45	48
HBL 71 B	230÷400T	4	3	14÷8,2	1400	82	Portata Delivery (m ³ /h)	24000	20000	10000	5000	2500	
HBL-X 71 B								24000	20000	10000	5000	2500	

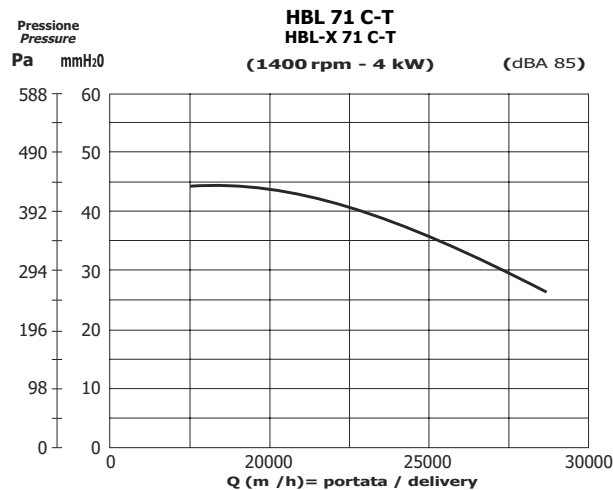

Modello Type	Vtaggio Voltage (V)	Potenza / Power		Assorbimento Absorption (A)	Giri/min. RPM	dBA	Pressione totale Total pressure	Pa	255	294	392	441
		HP	kW					mmH ₂ O	26	30	40	45
HBL 71 C	230÷400T	5,5	4	16,4÷10,6	1400	85	Portata Delivery (m ³ /h)	28500	27000	23000	10000	
HBL-X 71 C								28500	27000	23000	10000	

Ventilatori elicoidali / Helicoidal blower

CORRENTE ALTERNATA (c.a.) / ALTERNATE CURRENT (a.c.)

PRESTAZIONI / PERFORMANCES

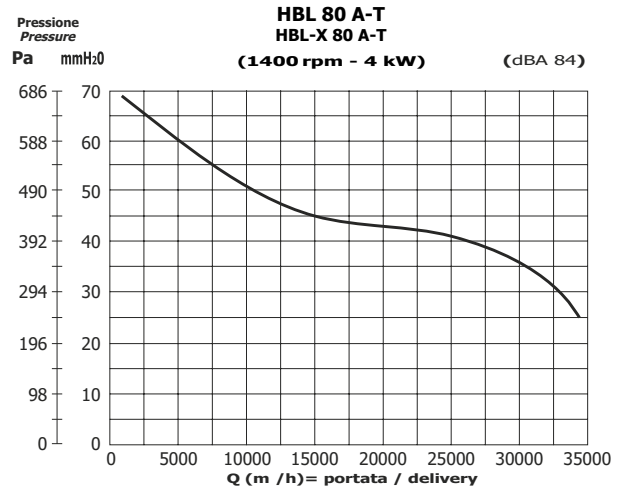
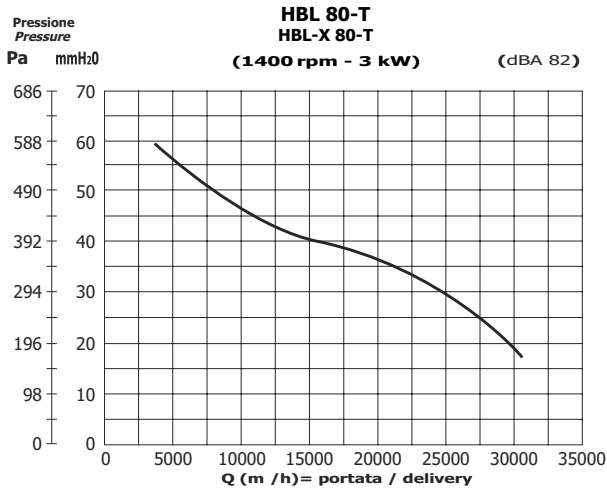

Modello Type	Vtaggio Voltage (V)	Potenza / Power		Assorbimento Absorption (A)	Giri/min. RPM	dBA	Pressione totale Total pressure	Pa	196	294	392	490	539
		HP	kW					mmH ₂ O	20	30	40	50	55
HBL 80 HBL-X 80	230÷400T	4	3	14÷8,2	1400	82	Portata Delivery (m ³ /h)		30900	25000	15000	7600	5100

Modello Type	Vtaggio Voltage (V)	Potenza / Power		Assorbimento Absorption (A)	Giri/min. RPM	dBA	Pressione totale Total pressure	Pa	294	343	392	588
		HP	kW					mmH ₂ O	30	35	40	60
HBL 80 A HBL-X 80 A	230÷400T	5,5	4,0	16,4÷10,6	1400	84	Portata Delivery (m ³ /h)		33000	30000	26000	5000

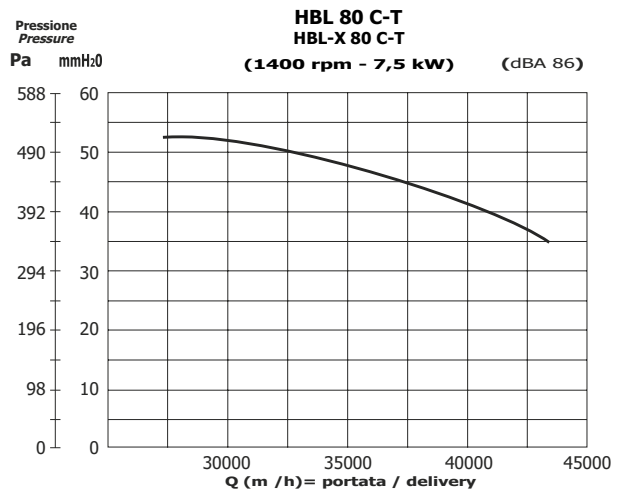
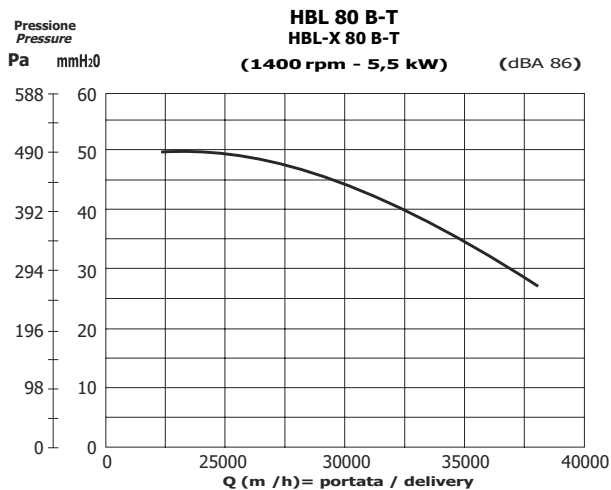

Modello Type	Vtaggio Voltage (V)	Potenza / Power		Assorbimento Absorption (A)	Giri/min. RPM	dBA	Pressione totale Total pressure	Pa	294	343	392	490
		HP	kW					mmH ₂ O	30	35	40	50
HBL 80 B HBL-X 80 B	230÷400T	7,5	5,5	20,6÷11,8	1400	86	Portata Delivery (m ³ /h)		38100	35000	33000	15000

Modello Type	Vtaggio Voltage (V)	Potenza / Power		Assorbimento Absorption (A)	Giri/min. RPM	dBA	Pressione totale Total pressure	Pa	343	392	490	539
		HP	kW					mmH ₂ O	35	40	50	55
HBL 80 C HBL-X 80 C	230÷400T	10	7,5	14,6÷8,4	1400	88	Portata Delivery (m ³ /h)		42900	41000	32500	27500

Ventilatori elicoidali / Helicoidal blower

CORRENTE ALTERNATA (c.a.) / ALTERNATE CURRENT (a.c.)

PRESTAZIONI / PERFORMANCES

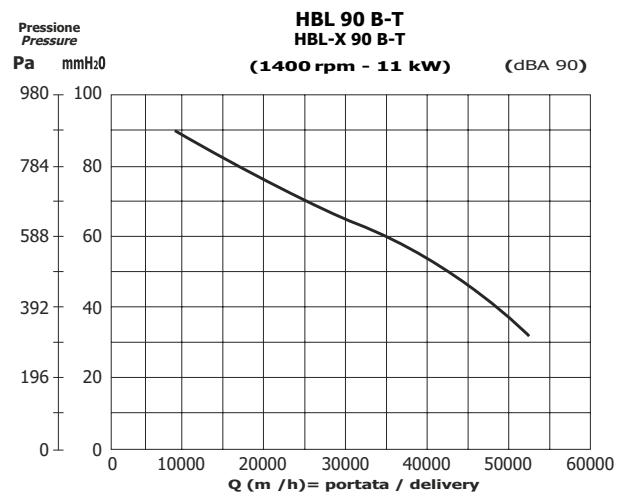
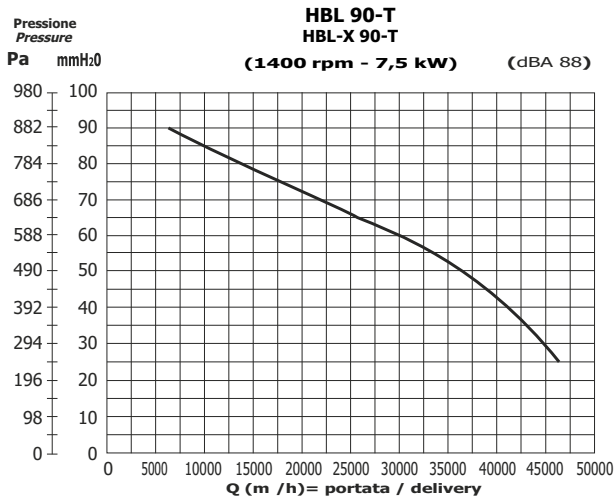

Modello Type	Vtaggio Voltage (V)	Potenza / Power		Assorbimento Absorption (A)	Giri/min. RPM	dBA	Pressione totale Total pressure	Pa	245	392	490	588	686	784	833
		HP	kW					mmH ₂ O	25	40	50	60	70	80	85
HBL 90 HBL-X 90	230÷400T	10	7,5	14,6÷8,4	1400	88	Portata Delivery (m ³ /h)	46000	41150	36100	30000	22000	13120	10000	

Modello Type	Vtaggio Voltage (V)	Potenza / Power		Assorbimento Absorption (A)	Giri/min. RPM	dBA	Pressione totale Total pressure	Pa	314	392	588	784
		HP	kW					mmH ₂ O	32	40	60	80
HBL 90 B HBL-X 90 B	230÷400T	15	11	22,3÷12,9	1400	90	Portata Delivery (m ³ /h)	52500	48000	35000	17500	

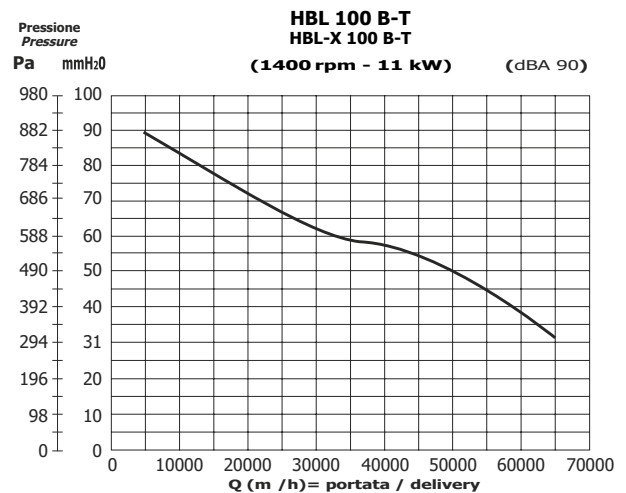
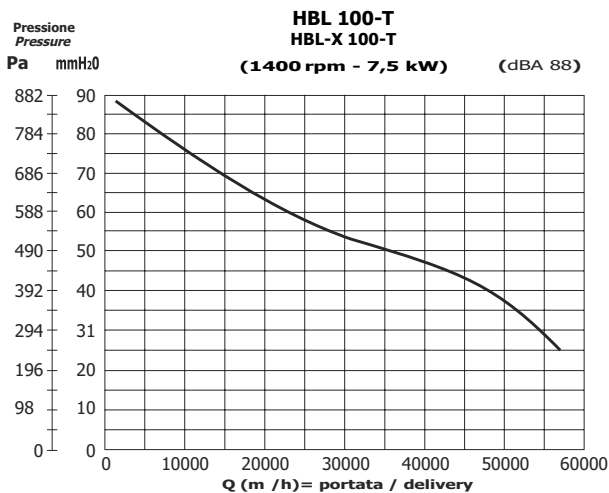

Modello Type	Vtaggio Voltage (V)	Potenza / Power		Assorbimento Absorption (A)	Giri/min. RPM	dBA	Pressione totale Total pressure	Pa	245	392	490	588	686	784
		HP	kW					mmH ₂ O	25	40	50	60	70	80
HBL 100 HBL-X 100	230÷400T	10	7,5	14,6÷8,4	1400	88	Portata Delivery (m ³ /h)	57000	48000	35000	23000	15000	7500	

Modello Type	Vtaggio Voltage (V)	Potenza / Power		Assorbimento Absorption (A)	Giri/min. RPM	dBA	Pressione totale Total pressure	Pa	294	441	490	637	686	784	833
		HP	kW					mmH ₂ O	30	45	50	65	70	80	85
HBL 100 B HBL-X 100 B	230÷400T	15	11	22,3÷12,9	1400	90	Portata Delivery (m ³ /h)	66000	55000	50000	26000	22000	13000	8400	

Ventilatori elicoidali / Helicoidal blower

CORRENTE ALTERNATA (c.a.) / ALTERNATE CURRENT (a.c.)

DIMENSIONI E PESI / DIMENSIONS AND WEIGHTS

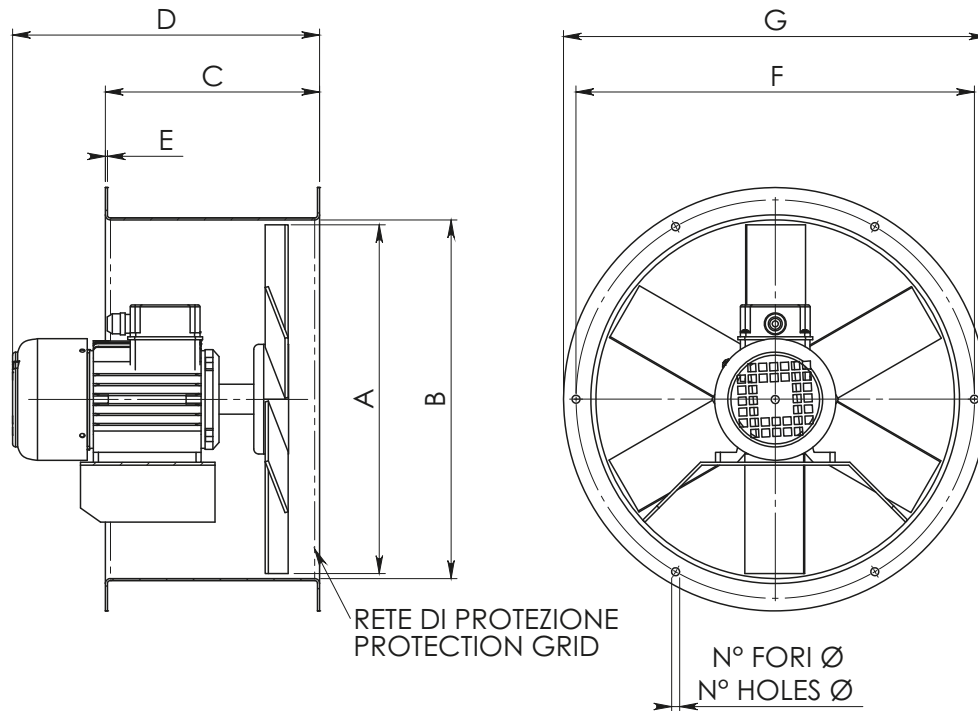

Modello Type	Corrente Current	A	B	C	D	E	F	G	Fori Holes	Peso Weight (kg)
HBL 21 - HBL-X 21	c.a. - a.c.	205	215	200	290	1,5	250	280	No.6 x Ø10	6
HBL 25 - HBL-X 25	c.a. - a.c.	250	260	200	300	1,5	285	315	No.6 x Ø10	7
HBL 30 - HBL-X 30	c.a. - a.c.	305	315	200	295	1,5	348	378	No.6 x Ø11	9
HBL 30/2 - HBL-X 30/2	c.a. - a.c.	305	315	200	330	1,5	348	378	No.6 x Ø11	12
HBL 35 - HBL-X 35	c.a. - a.c.	350	360	215	295	1,5	400	425	No.6 x Ø11	10
HBL 35/2 - HBL-X 35/2	c.a. - a.c.	350	360	215	400	1,5	400	425	No.6 x Ø11	13
HBL 40 - HBL-X 40	c.a. - a.c.	400	410	215	330	1,5	440	473	No.6 x Ø11	12
HBL 40/2 - HBL-X 40/2	c.a. - a.c.	400	410	220	410	1,5	440	473	No.6 x Ø11	15
HBL 45 - HBL-X 45	c.a. - a.c.	450	460	230	330	1,5	495	523	No.6 x Ø11	14
HBL 45/2 - HBL-X 45/2	c.a. - a.c.	450	460	230	410	1,5	495	523	No.6 x Ø11	20
HBL 45/2 B - HBL-X 45/2 B	c.a. - a.c.	450	460	230	410	1,5	495	523	No.6 x Ø11	21
HBL 50 - HBL-X 50	c.a. - a.c.	500	510	270	400	1,5	545	573	No.8 x Ø11	21
HBL 50/2 - HBL-X 50/2	c.a. - a.c.	500	510	270	510	1,5	545	573	No.8 x Ø11	34
HBL 56 - HBL-X 56	c.a. - a.c.	560	570	300	400	1,5	605	633	No.8 x Ø11	24
HBL 63 - HBL-X 63	c.a. - a.c.	630	640	300	420	2	675	704	No.8 x Ø11	27
HBL 71 - HBL-X 71	c.a. - a.c.	700	710	300	450	2	745	774	No.12 x Ø 14	48
HBL 71 B - HBL-X 71 B	c.a. - a.c.	700	710	300	510	2	745	774	No.12 x Ø 14	58
HBL 71 C - HBL-X 71 C	c.a. - a.c.	700	710	300	530	2	745	774	No.12 x Ø 14	62
HBL 80 - HBL-X 80	c.a. - a.c.	800	810	350	510	2	855	884	No.12 x Ø 14	60
HBL 80 A - HBL-X 80 A	c.a. - a.c.	800	810	350	510	2	855	884	No.12 x Ø 14	65
HBL 80 B - HBL-X 80 B	c.a. - a.c.	800	810	350	540	2	855	884	No.12 x Ø 14	70
HBL 80 C - HBL-X 80 C	c.a. - a.c.	800	810	350	640	2	855	884	No.12 x Ø 14	84
HBL 90 - HBL-X 90	c.a. - a.c.	900	910	500	680	3	955	1004	No.16 x Ø 14	135
HBL 90 B - HBL-X 90 B	c.a. - a.c.	900	910	500	680	3	955	1004	No.16 x Ø 14	150
HBL 100 - HBL-X 100	c.a. - a.c.	1000	1010	500	680	3	1070	1104	No.16 x Ø 14	155
HBL 100 B - HBL-X 100 B	c.a. - a.c.	1000	1010	500	680	3	1070	1104	No.16 x Ø 14	165

Misure in millimetri (mm), dimensioni non impegnative / Measures in millimeter (mm), dimensions approximated

Ventilatori elicoidali / Helicoidal blower

DIREZIONI DI FLUSSO ED ESECUZIONI / FLUX DIRECTIONS AND EXECUTIONS

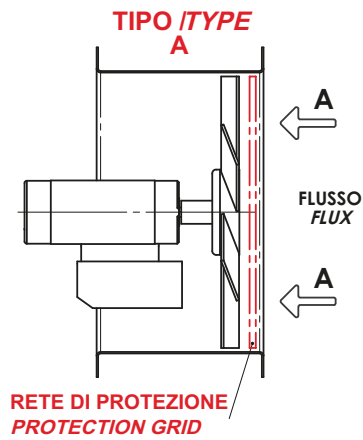

Flusso A : Ventilatore
A flux : Ventilator

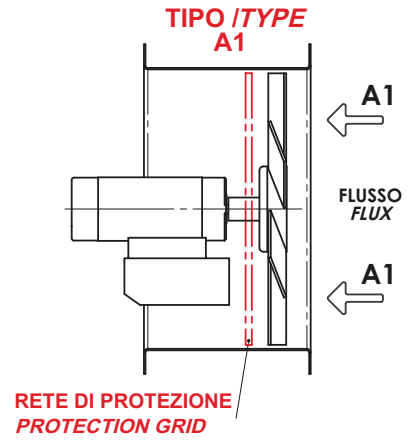

Flusso A1 : Ventilatore
A1 flux : Ventilator

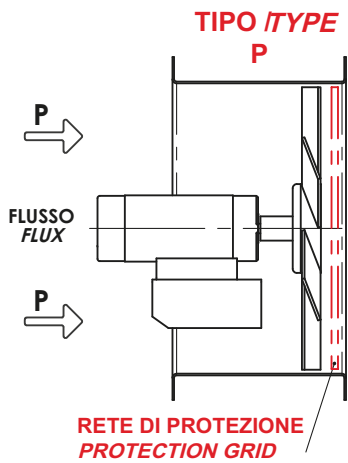

Flusso P : Estrattore
P flux : Extractor

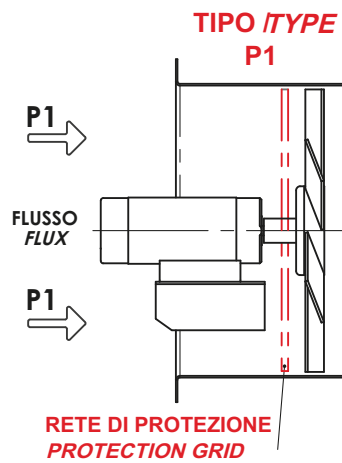

Flusso P1 : Estrattore
P1 flux : Extractor

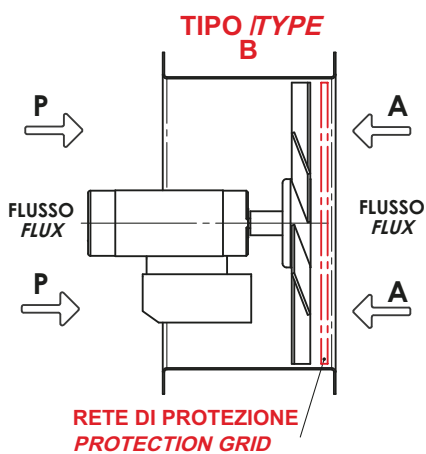

Flusso B : Bi-direzionale (A+P)
B flux : Bi-directional (A+P)

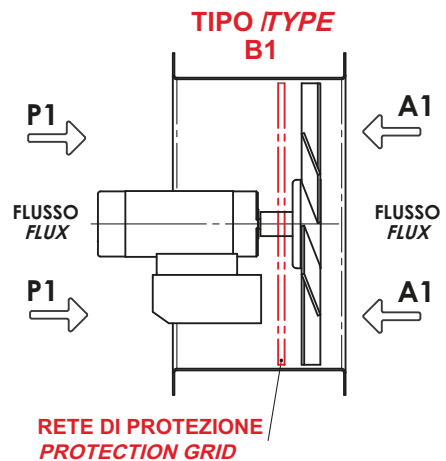

Flusso B1 : Bi-direzionale (A+P)
B flux : Bi-directional (A+P)

Accessori per ventilatori / Accessories for blowers



Anello antivibrante: anello flessibile in gomma EPDM anti-vibrazioni, con doppia flangia interna in acciaio inox, comunemente usato per assorbire le vibrazioni e ridurre il livello di rumore generato quando il ventilatore è in funzione.

Vibration damping ring: Flexible vibration damping ring, made of EPDM rubber, with a double internal flange made of stainless steel, commonly used to absorb the vibrations and consequently to reduce the noise level generated when the blower is working.



Raccordo quadro/tondo: realizzato in alluminio, è utilizzato per collegare il ventilatore alla serranda.

Square/round adaptor: made in aluminium, they are used to connect the blower with the dumper.



Flangia a soffietto: Utilizzate per evitare il propagarsi delle vibrazioni dal ventilatore alle canalizzazioni. Possono essere applicate sia in aspirazione che in mandata.

Circular flexible flange: Used to avoid the vibrations from the blowers to the pipes and can be fitted both in the inlet and in the outlet of the blowers.



Silenziatori cilindrici: Utilizzati per l'abbattimento della pressione sonora prodotta dal ventilatore. Disponibili in acciaio zincato o in acciaio INOX (a richiesta con ogiva interna).

Cylindrical silencers: Used for the abatement of the sound pressure. Available in galvanized steel or Stainless steel (with internal ogive on request).