

Elettropompe centrifughe monoblocco con girante aperta non autoadescanti in bronzo largamente utilizzate nel settore nautico per i servizi di circolazione liquidi, impianti di condizionamento e raffreddamento. Per liquidi moderatamente carichi di impurità

Close-coupled centrifugal not selfpriming electric pumps made of bronze with open impeller. These pumps are widely used in the nautical sector for liquid circulation, air conditoning, cooling. For moderately dirty liquids or emulsions.



	3ph		1ph		P ₂ kw	Q M3/h																	
	230V A	400V A	230V A	giri rpm			0,6	0,9	1,2	1,5	1,8	2,4	3	3,6	4,8	6	6,6	8,4	9,6	10,8	12	13,2	15
LCB16/1E	1,7	1	1,2	2800	0,15		5	4,7	4,4	4,2	4	3,6											
LCB 20/E	2,3	1,3	2,8	2800	0,37					12,3	12,2	12	11,5	10,8	9								
LCB 22/E	3	1,7	4,5	2800	0,55	H m				21	21	20,5	20	19,5	17,5	13	10						
LCB41/1E	4	2,3	5,8	2800	0,75									19	18,8	18,5	18,3	17,7	17,4	16,8	16	15	13
LCB 41/E	5	2,9	7,4	2800	1,5									23,5	23,1	22,5	22	21	20	18,5	17	15,5	14

P₂ Potenza nominale motore

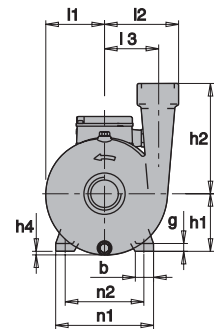
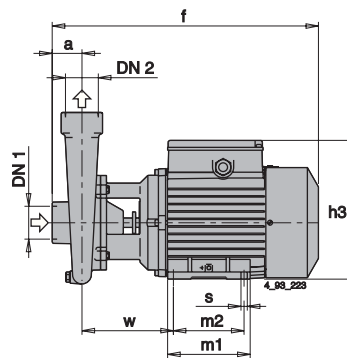
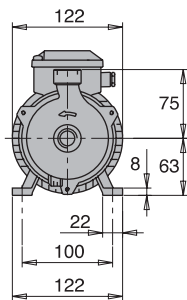
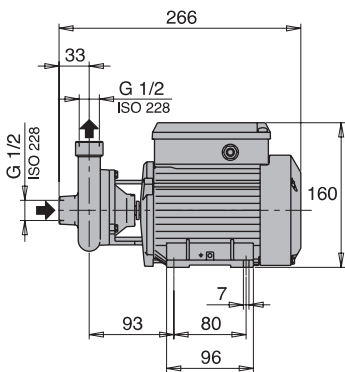

TIPO	KG
LCB 16/1E	5

LCB 20/E ... LCB 41E

	DN ₁ ISO 228	DN ₂ ISO 228	mm																	kg 220/380V	kg 220V
			a	f	h ₁	h ₂	h ₃	h ₄	m ₁	m ₂	n ₁	n ₂	b	s	l ₁	l ₂	l ₃	w	g		
LCB 20/E	G 1	G 1	35	303	71	90	177	-	106	90	134	112	22	7	70	84	60	105	10	9,1	9,1
LCB 22/E	G 1	G 1	35	303	71	110	177	9	106	90	134	112	22	7	81	93	71	106	10	9,6	10,6
LCB 41/1E	G 1 1/2	G 1 1/2	43	380	80	160	208	9	125	100	155	125	30	9,5	85	108	78	132	10	16,3	17,9
LCB 41/E	G 1 1/2	G 1 1/2	43	380	80	160	208	9	125	100	155	125	30	9,5	85	108	78	132	10	19,2	20,1

