

Elettropompe centrifughe autoadescanti in bronzo (adescamento lento) a girante aperta largamente utilizzate nel settore nautico per i servizi di svuotamento di sentine, antincendio, lavaggio catene, travaso di gasolio, ecc. La conformazione della girante permette il passaggio di liquido anche con piccoli corpi solidi in sospensione fino a 4,5 mm per AML 40.

*Centrifugal selfpriming electric pumps made of bronze (slow priming) with open impeller. These pumps are widely used in the nautical sector to empty bilges, to supply anti-fire equipment, to wash chains and for diesel oil transfer. The impeller shape allows the transferring of liquids with small solid parts in suspension up to 4,5 mm grain size for AML 40.*

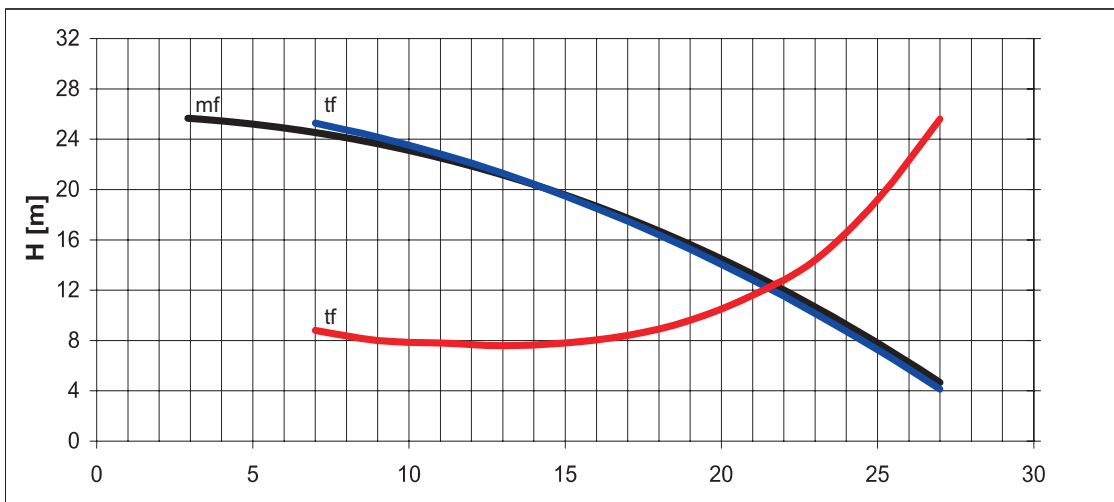

Tolleranze secondo ISO 2548 classe C	AML 40 - mf 2,2 kW		AML 40 - tf 3 kW		Tolerances according ISO 2548 C class
<b>Velocità di rotazione [giri/min]</b>	<b>2900</b>		<b>2900</b>		<b>Rotating speed [rpm]</b>
Densità dell'acqua alla prova	1000	kg/m <sup>3</sup>	1000		Water density at test
Passaggio corpi solidi (max diametro sfera)	4,5	mm	4,5		Solid handling (max.diameter sphere)
Diametro girante	149	mm	149		Impeller diameter
Altezza di innesco massima	4,5	m	4,5		Maximum priming lift
Tipo motore di azionamento	monofase/Singlephase		trifase/Threephase		Driving motor type
Frequenza/tensione collegamento stella/triangolo	50 / 230	Hz/V	50 / 400 / 230		Frequency /star / delta connection voltage
Corrente nominale collegamento stella/triangolo	13,8	A	6,7/11,6		Nominal current star / delta connection
Potenza installata	2,2	kW	3		Rated power
Massa della pompa	41	kg	39		Pump mass



**H(Q)**  
 Prevalenza totale  
 Total head

**NPSHr**  
 NPSH richiesto  
 Required NPSH

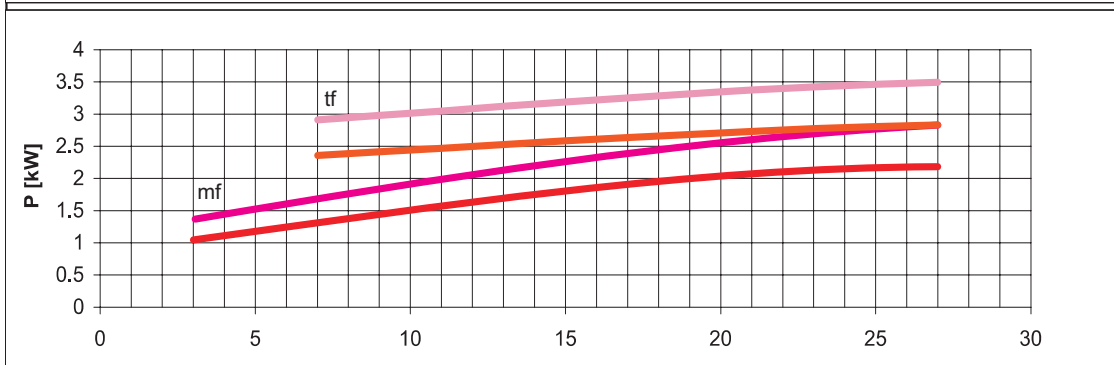

**P1**  
 Potenza assorbita dalla rete  
 Required power from mains

**P2**  
 Potenza richiesta all'albero  
 Required power at shaft

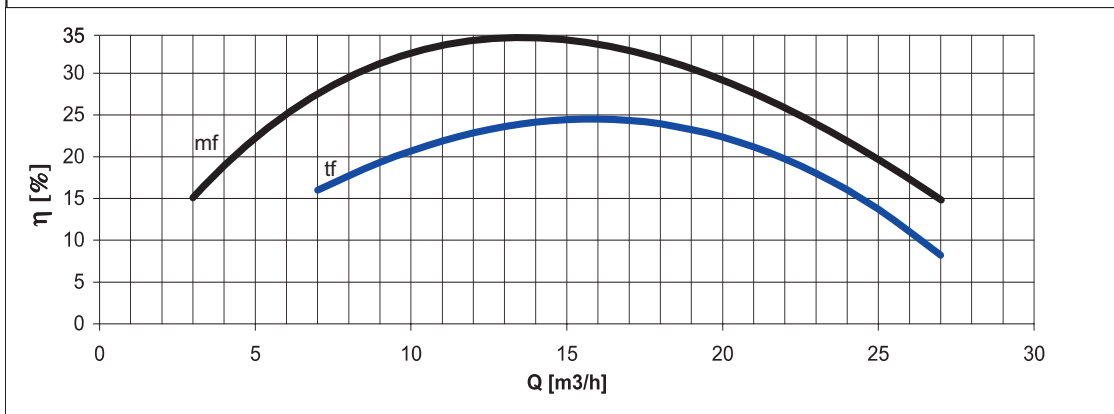

**η**  
 Rendimento gruppo  
 Global unit efficiency

# AML 40 - mf 2,2 kW - tf 3 kW

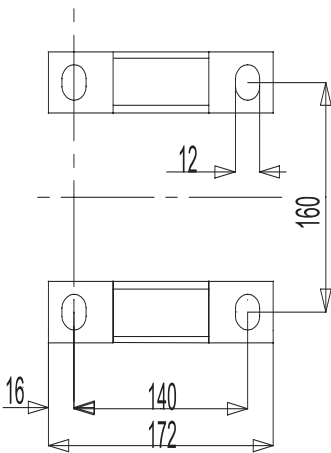
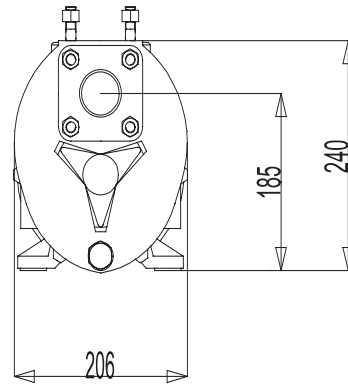
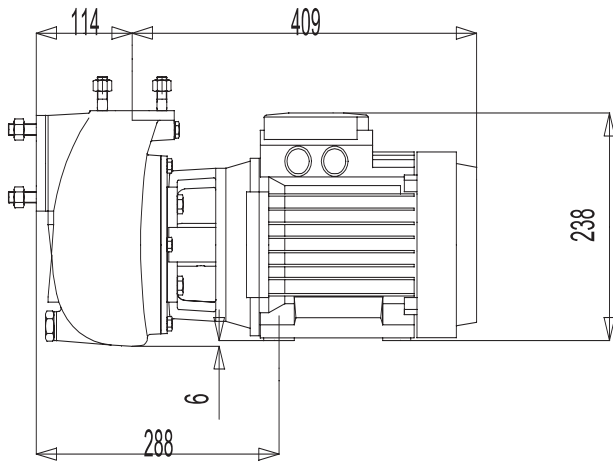

Dimensioni piedi

Flangia mandata

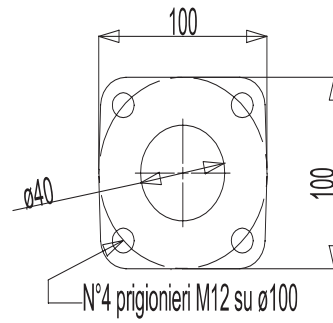

Flangia aspirazione

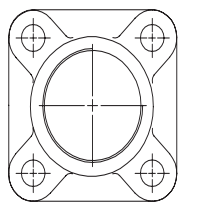
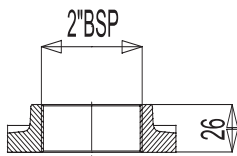
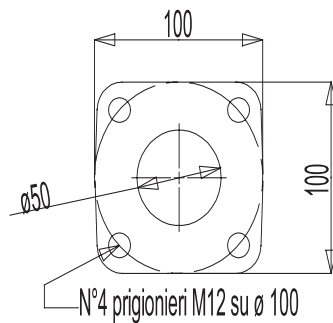

Controflangia aspirazione

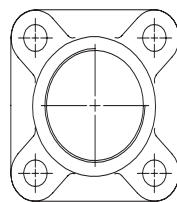
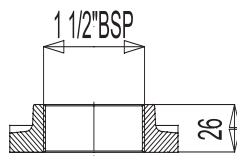

Controflangia mandata