

Elettropompe centrifughe autoadescanti tipo Jet a girante chiusa dalla elevata capacità di aspirazione.

La serie BJ con corpo in bronzo è idonea al trasferimento di acqua dolce e di mare.

Selfpriming centrifugal electric pumps, Jet type, with closed impeller featuring a high suction capacity.

BJ models, with bronze body, are suitable for fresh and sea water.



	3ph		1ph		P ₂ kw	Q M ³ /h																			
	230V A	400V A	230V A	giri rpm			0,25	0,5	1	1,5	2	2,5	3	3,5	4	4,5	5	5,5	6	7	8	9	9,5		
BJ 3	3	1,7	4,5	2800	0,55	H m	4,1	8,3	16,6	25	33,3	41,6	50	58,3	66,6	75	83,3	91,6	100	116	133	150	158		
BJ 4	3,7	2,2	5,7	2800	0,75		49	45	40	36	32	28	24												
BJ 5	5	2,9	7,4	2800	1,1		41	39	36	33	31	29	26	24	21										
BJ 6	7,5	4,3		2800	1,5		48,5	46	43,5	41,5	39,5	38	35,5	34	32	30,5	29	28							
			9,2	2800	1,5		51,5	50	48,5	47	46	44,5	43	41,5	40	39	37,5	36,5	33,5	31	28,5	27			
BJ 7	9,1	5,3		2800	2,2		47	45	43,5	42	41	40	38	37	36	35	33	32	30	27	24	23			
							59	57,5	56,5	55	54	52,5	51	50	48,5	47	45,5	44	41,5	38	35	34			

P₂ Potenza nominale motore / Rated motor power output

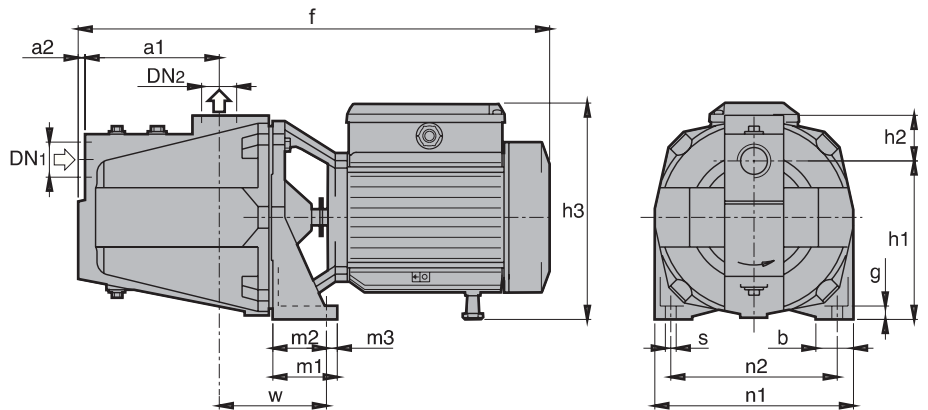
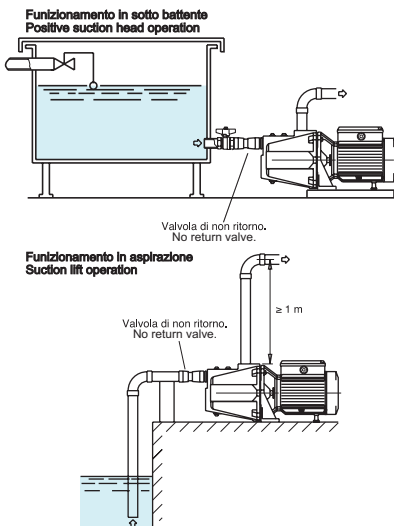

	mm																	kg	
	DN ₁	DN ₂	a ₁	a ₂	f	h ₁	h ₂	h ₃	m ₁	m ₂	n ₁	n ₂	b	s	l ₁	l ₂	w		g
BJ 3	G1	G1	127	8	430	150	43	203	60	52	185	155	35	9,5	-	-	100	11	20,8
BJ 4	G1	G1	127	8	430	150	43	203	60	52	185	155	35	9,5	-	-	100	11	21,5
BJ 5	G1 _{1/2}	G1	160	10	560	165	57	215	60	50	215	175	40	11,5	-	-	115	11	31,6
BJ 6	G1 _{1/2}	G1	160	10	560	165	57	215	60	50	215	175	40	11,5	-	-	115	11	32,9
BJ 7	G1 _{1/2}	G1	160	10	600	165	57	215	60	50	215	175	40	11,5	-	-	115	11	33,4

